

SKEMA

INDOOR



SKEMA

Superfici da vivere, dal 1992
Living surfaces, since 1992

Azienda Company

**Superfici d'eccellenza
per spazi contemporanei**
Outstanding surfaces
for contemporary spaces

Skema nasce nel 1992 in provincia di Treviso e da più di trent'anni propone superfici in legno, SPC, laminato e decking destinate alla casa, all'ufficio e al contract, all'interno e all'esterno degli edifici. Pavimenti, pareti e soffitti vengono proposti con finiture e materiali perfezionati in anni di esperienza, rispettando la salute dell'ambiente e delle persone. L'estrema attenzione al comfort ambientale ha portato alla creazione di una divisione di rivestimenti fonoassorbenti da parete e soffitto in perfetta continuità estetica e materica con le collezioni dei pavimenti. Passione, esperienza e gusto sono le parole chiave che animano ogni scelta aziendale e ogni rapporto con clienti italiani ed esteri.

Skema was founded in 1992 in the province of Treviso and, for more than thirty years, has been offering wood, SPC, laminate and decking surfaces designed for residential, office, and contract projects, both indoors and outdoors. Floors, walls, and ceilings are proposed with finishes and materials refined through years of expertise, always with full respect for environmental sustainability and human well-being. A strong focus on indoor comfort has led to the development of a dedicated division of sound-absorbing wall and ceiling coverings, conceived in perfect aesthetic and material continuity with the flooring collections. Passion, experience, and style are the key values driving every corporate choice and every relationship with both Italian and international clients.



Pavimenti e rivestimenti perfettamente ingegnerizzati attraverso processi tecnologici che combinano le caratteristiche fisico-meccaniche di legni e polimeri.

Soluzioni tecniche ed estetiche applicabili ad ambienti residenziali e direzionali, interni ed esterni.

Floors and coverings perfectly engineered through technological processes that combine the physical and mechanical properties of wood and polymers. Technical and aesthetic solutions applicable to all surfaces in residential and commercial environments, both indoors and outdoors.

SUPERFICI
SURFACES



POSA
LAYING



SPAZI
SPACES

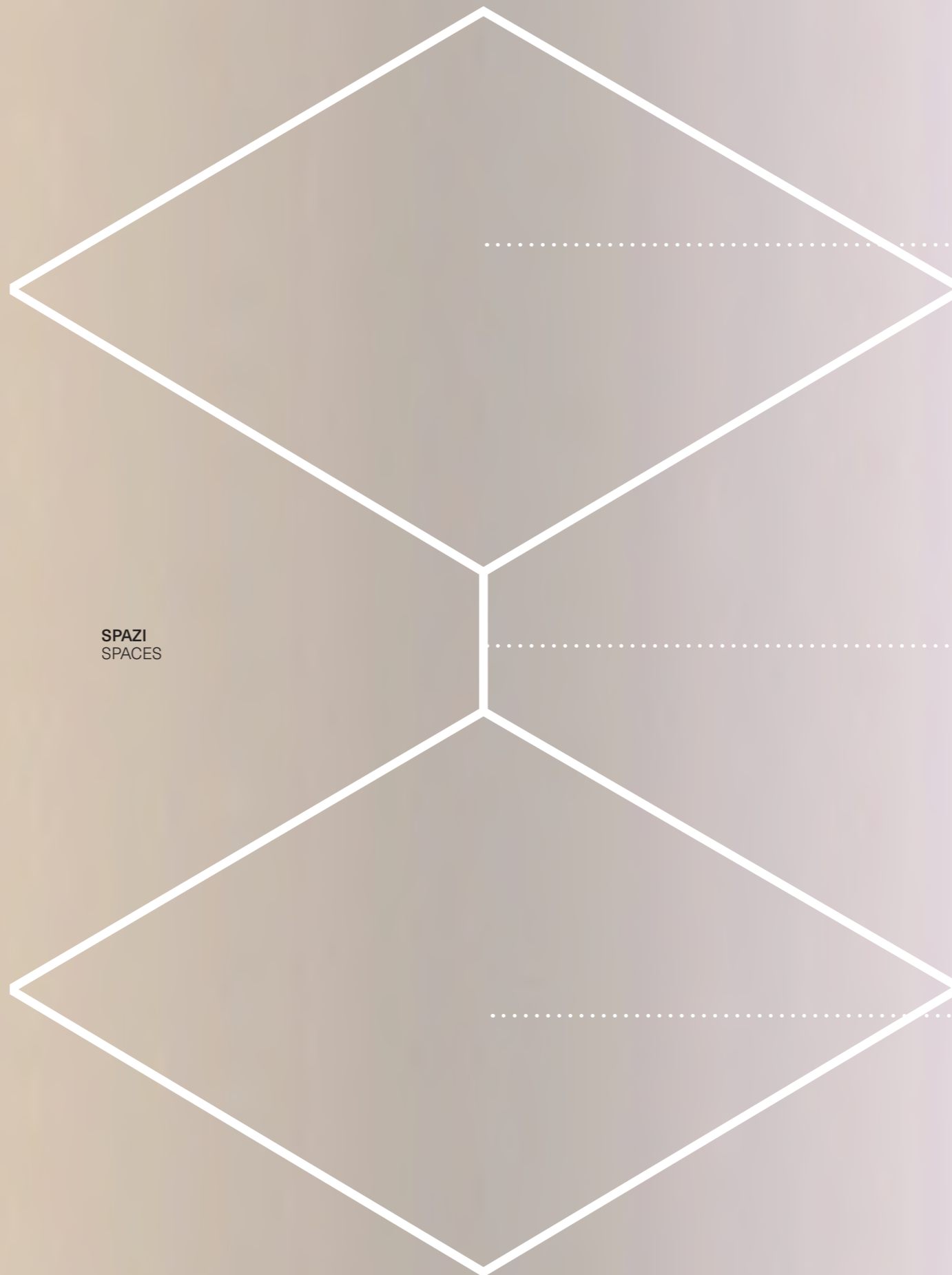

SOFFITTO
CEILING

legno
superfici tecniche
wood
technical surfaces

PARETE
WALL

legno
superfici tecniche
SPC
decking
wood
technical surfaces
SPC
decking

PAVIMENTO
FLOOR

legno
pavimenti tecnici
SPC
decking
wood
technical floorings
SPC
decking

CONTENUTI TOPICS

AZIENDA COMPANY

Undici step per garantire l'eccellenza del prodotto Eleven steps to ensure product excellence

Un concentrato di tecnologia A concentration of technology

Incastri Joints

Skema services

Skema project

Retail services

PAVIMENTI IN LEGNO WOODEN FLOORING

Yles

Palladio

Villa

Lumbertech

PROGRAMMA LIVE LIVE PROGRAM

Pavimenti in legno personalizzati Customized wood flooring

PAVIMENTI TECNICI TECHNICAL FLOORING

K-Uno

Prestige Gold

Prestige L

Facile +

Syncro Parquet

Vision Oxid

Vision Technic

002

008

010

011

012

014

015

016

018

030

042

054

078

080

082

084

098

118

130

150

158

170

PAVIMENTI IN SPC SPC FLOORING

Star K

Star KR

Star KC

Star KS

Star KD

Connex

Star Wood

PAVIMENTI SOPRAELEVATI RAISED FLOORING

Top Level Lumbertech

Top Level Prestige L

Top Level Vision Technic

RIVESTIMENTI A PARETE E SOFFITTO WALL AND CEILING COVERINGS

Tech Wall

Star KW

Star KW Maxi

ACCESSORI ACCESSORIES

Sottopavimenti Underlays

Battiscopa Skirting boards

Profili Profiles

Accessori per pavimenti sopraelevati Accessories for raised floors

Accessori per rivestimenti a parete e soffitto Accessories for wall and ceiling coverings

Posa Laying

Cura e manutenzione Care and maintenance

PACKAGING E LOGISTICA PACKAGING AND LOGISTICS

178

180

192

204

214

220

232

242

254

256

264

272

278

280

300

308

320

322

323

326

333

334

335

338

340

Undici step per garantire l'eccellenza del prodotto

Eleven steps to ensure product excellence

Skema verifica la conformità dei propri prodotti Indoor e Outdoor con undici step di controllo. Si avvale inoltre di importanti enti e laboratori nazionali e internazionali per certificare le prestazioni dell'intera gamma prodotti, in particolare negli ambiti della conformità legale, della sicurezza, della sostenibilità, della salubrità e della qualità.

Skema verifies the conformity of its Indoor and Outdoor products with eleven control steps. It also uses major national and international bodies and laboratories to certify the performance of its entire product range, particularly in the areas of legal compliance, safety, sustainability, health and quality.

01

**CONTROLLO DELLE DIMENSIONI
E DEL PESO**
SIZE AND WEIGHT CHECKS

Verifichiamo che lunghezza, larghezza, spessore e densità in kg/m³ coincidano con quelle dichiarate nelle schede tecniche.

We check that the length, width, thickness and density in kg/m³ coincide with those stated in the technical data sheets.

04

**CONTROLLO DEL CONTENUTO
DI UMIDITÀ**
MOISTURE CONTENT CHECKS

Un test strumentale consente di verificare il contenuto di umidità della doga, su entrambe le facce.

An instrumental test is used to check the moisture content of the plank, on both faces.

02

**CONTROLLO DELLA FUNZIONALITÀ
DEGLI INCASTRATI**
CHECKING THE FUNCTIONALITY
OF THE JOINTS

Eseguiamo una prova di montaggio per verificare la funzionalità degli incastri e assicurare la coplanarità tra le doghe.

We carry out an assembly test to check the functionality of the joints and ensure coplanarity between the planks.

05

**CONTROLLO DELLA REAZIONE
AL CALORE E ALL'UMIDITÀ**
CHECKING THE REACTION TO HEAT
AND HUMIDITY

Valutiamo la reazione termo-igrometrica dell'elemento attraverso una serie di test a temperature e gradi di umidità controllati.

We evaluate the reaction of the element to heat and humidity through a series of tests at controlled temperatures and humidity levels.

03

**CONTROLLO DEL PROFILO DEGLI
INCASTRATI**
CHECKING THE PROFILE OF THE JOINTS

Usiamo un proiettore per verificare che il profilo dell'incastro sia esattamente identico a quello del campione originario.

We use a comparator to check that the profile of the joint is exactly the same as the original sample.

06

**CONTROLLO DELLA RESISTENZA
CHIMICA**
CHEMICAL RESISTANCE CHECKS

Verifichiamo la resistenza della superficie quando entra in contatto con sostanze convenzionali come acqua, ammoniaca, candeggina, olio, aceto e caffè.

We test the resistance of the surface when it comes into contact with conventional substances, such as water, ammonia, bleach, oil, vinegar and coffee.

07

**CONTROLLO DELLA RESISTENZA
MECCANICA**
MECHANICAL STRENGTH CHECKS

Verifichiamo la resistenza della superficie usando il taber test e il metodo della "quadrettatura", che prevede l'applicazione di nastro adesivo su un'area incisa a reticolo per valutare la tenuta della vernice.

We check the resistance of the surface using the taber test and the "grid" method, whereby adhesive tape is applied to a gridded area to assess the resistance of the paint.

10

CONTROLLO DELLA FINITURA
FINISHING CHECKS

Usiamo i campioni master per verificare che colore e struttura della finitura coincidano.

We use master samples to check that the colour and texture of the finish match.

08

**CONTROLLO DELLA RESISTENZA
ALL'URTO**
IMPACT RESISTANCE CHECKS

Misuriamo la deformazione generata dall'impatto di una sfera metallica sulla superficie di una doga.

We measure the deformation generated by the impact of a metal ball on the surface of a plank.

11

**CONTROLLO DELLA RESISTENZA
ALL'ACQUA**
WATER RESISTANCE CHECKS

Verifichiamo la variazione dimensionale del campione dopo l'immersione parziale in acqua di 24 ore.

We check the dimensional change of the sample after partial immersion in water for 24 hours.

09

**CONTROLLO DELLA RESISTENZA
AI GRAFFI**
SCRATCH RESISTANCE CHECKS

Verifichiamo la profondità dell'incisione causata da una punta di diamante soggetta a forza controllata.

We check the depth of the engraving caused by a diamond tip subjected to controlled force.

Un concentrato di tecnologia

A concentration of technology

L'evoluzione dei pavimenti Skema passa attraverso soluzioni tecnologiche che migliorano estetica, prestazioni e facilità di posa. Dai sistemi di incastro di nuova generazione alle superfici sincronizzate con la matericità del legno, fino ai trattamenti che incrementano la resistenza all'acqua e alle sollecitazioni, ogni tecnologia contribuisce a rendere questi materiali più affidabili, realistici e performanti. È la costante azione di ricerca e la volontà di un reale miglioramento continuo che danno sostanza ai prodotti e diventano garanzia di qualità per i clienti.

The evolution of Skema flooring is driven by technological solutions that enhance aesthetics, performance, and installation ease. From new-generation locking systems to surfaces synchronized with the natural texture of wood, and treatments that increase resistance to water and stress, each technology contributes to making these materials more reliable, realistic, and high-performing. Continuous research and a genuine commitment to constant improvement give real substance to our products and become a guarantee of quality for our customers.

SYNCRO

La tecnologia applicata a pavimenti tecnici e SPC per semplificare la posa a spina di pesce.

Technology applied to technical floors and SPCs to make herringbone laying easier.

HYDRO

La tecnologia Hydro rende le superfici sempre più resistenti all'acqua.

Hydro technology makes our surfaces more water-resistant.

SINCROPORO

SYNCROPOROUS

Una tecnologia di stampa che dà al materiale effetto legno un aspetto realistico e una sensazione tattile.

A technology that gives the wood effect material a very realistic look and feel.

INCASTRO

INTERLOCKING

5G™, 5Gi™, 5Gdry, Unidrop, I4F, TLS PF, TLS PLUS, PLS: tecnologie all'avanguardia per pose perfette.

5Gc, 5Gi, 5Gdry, Unidrop, I4F, TLS PF, TLS PLUS, PLS: cutting-edge technologies for perfect laying.

WOOD POWDER

Un composto che rende le doghe in Lumbertech più resistenti a calpestio, urti e picchi di carico.

A compound that makes Lumbertech planks more resistant to footsteps, impacts and load peaks.

Incastri

Joints

5G

I prodotti della famiglia STAR adottano un sistema già noto ai clienti Skema trattandosi del brevetto 5G™. La posa è molto facilitata ed avviene con un solo movimento, ovvero nello stesso tempo viene agganciata la doga al pavimento già posato sul lato lungo e, proseguendo nell'azione di abbassamento, la doga si aggancia di testa all'elemento di fianco già posato. La tenuta dell'incastro viene garantita dalla plastica con effetto a molla che, una volta scattata in sede, impedisce lo sfilamento della doga sia verso l'alto che sul piano orizzontale.

Lo scatto è accompagnato dalla emissione di un effetto sonoro che possiamo riassumere in un rassicurante "click".

È stato verificato che il 5G™ permette una riduzione sensibile dei tempi di posa in confronto ai sistemi più tradizionali.

The family products STAR adopt a locking system already known to Skema's customers, the 5G™ patent. The installation is very easy and made with a single movement, at the same time the plank is hooked on the long side to the floor already laid down and, continuing the putting down action, the plank is hooked at the head to the side element already laid. The joint is held in place by the spring effect plastic element. Once snapped into its place, it prevents the slipping off of the plank both upwards and horizontally. The click is accompanied by the emission of a sound effect that can be summed up in a reassuring "click". It has been verified that the 5G™ allows a significant reduction in installation compared to more traditional systems.

I4F

5Gi

UNIDROP

I4F™, 5Gi™ e UNIDROP™ sono incastri brevettati della famiglia Fold Down nella versione speciale "push-down", che danno il meglio di sé nei prodotti SPC. A differenza del fold down tradizionale, non prevedono inserti di plastica e attivano la tenuta delle parti sia per elasticità propria del materiale, che permette il mutuo inserimento di maschio e femmina, sia per conformazione della sezione che, per contrasto e sottosquadra delle due parti agganciate garantisce una tenuta ottimale. La sicurezza di incastro avvenuto si ottiene con l'impiego del martello di gomma sul lato doga appena posata. Non battere sul lato doga precedente.

I4F™, 5Gi™ and UNIDROP™ are patented joints of the Fold Down family in the special "push-down" version, which express them best in SPC products. Instead of the traditional fold down, they do not have plastic inserts and activate the seal of the parts both for the elasticity of the material, that allows the mutual insertion of male and female, both for the conformation of the section and for the contrast and undercuts of the two joined parts guaranteeing an optimal resistance.

The safety of interlocking is obtained with the use of the rubber hammer on the plank's side just laid. Do not beat on the previous plank side.



Skema services

Skema si propone ad architetti, rivenditori, contractor e interior designer come partner di progetto, non solo come fornitore del prodotto. Per questo offre una serie di servizi che supportano il cliente in ogni fase della realizzazione, con l'unico obiettivo di raggiungere il miglior risultato.

Skema is a project partner and not just a product supplier for architects, retailers, contractors and interior designers. That is why it offers a range of services that support the customer at every stage of implementation, with the sole objective of achieving the best result.

ASSISTENZA AL CLIENTE CUSTOMER ASSISTANCE



Con una rete di rivenditori capillare in Italia e una presenza in crescita costante all'estero, l'assistenza pre e post vendita è assicurata sia a livello nazionale sia internazionale. Inoltre, Skema offre un servizio di customer care via telefono, email, videocall e social media.

With an extensive dealer network in Italy and a steadily growing presence abroad, pre and after sales support is provided both nationally and internationally. In addition, Skema offers a customer care service via telephone, e-mail, videocall and social media.

LOGISTICA LOGISTICS



Fiore all'occhiello dell'azienda è l'organizzazione della logistica. Uffici efficienti e un magazzino organizzato permettono a qualsiasi prodotto di essere spedito in modo facile e veloce, con la sicurezza che arriverà al cliente finale nei tempi e nei modi previsti.

The flagship service of the company is the organisation of logistics. Efficient offices and an organised warehouse make it possible to ship any product quickly, with the assurance that it will reach the end customer on time and by the methods agreed on.

NETWORK DI POSATORI FORMATI NETWORK OF TRAINED INSTALLERS



La bellezza di un pavimento dipende anche dalla qualità della posa. Per questo Skema si affida a un network di posatori qualificati, formati attraverso corsi interni che li tengono sempre aggiornati sulle ultime novità del settore.

The beauty of a floor also depends on the quality of its installation. This is why Skema relies on a network of qualified installers, trained through internal courses that keep them constantly updated on the latest developments in the industry.

GARANZIA SUL PRODOTTO PRODUCT WARRANTY



Garanzia specifica in base alla tipologia di prodotto, ed eventuale sostituzione di prodotti non conformi.

Specific warranty depending on the type of product, and possible replacement of non-compliant.

DOCUMENTAZIONE TECNICA TECHNICAL DOCUMENTATION



L'ufficio tecnico di Skema predispone tutta la documentazione necessaria: dalle certificazioni di prodotto alle marcature CE, dalle etichette ambientali alla documentazione CAM per il settore pubblico.

Skema's technical department prepares all the necessary documentation: from product certifications to CE markings, from environmental labels to MEC documentation for the public sector.

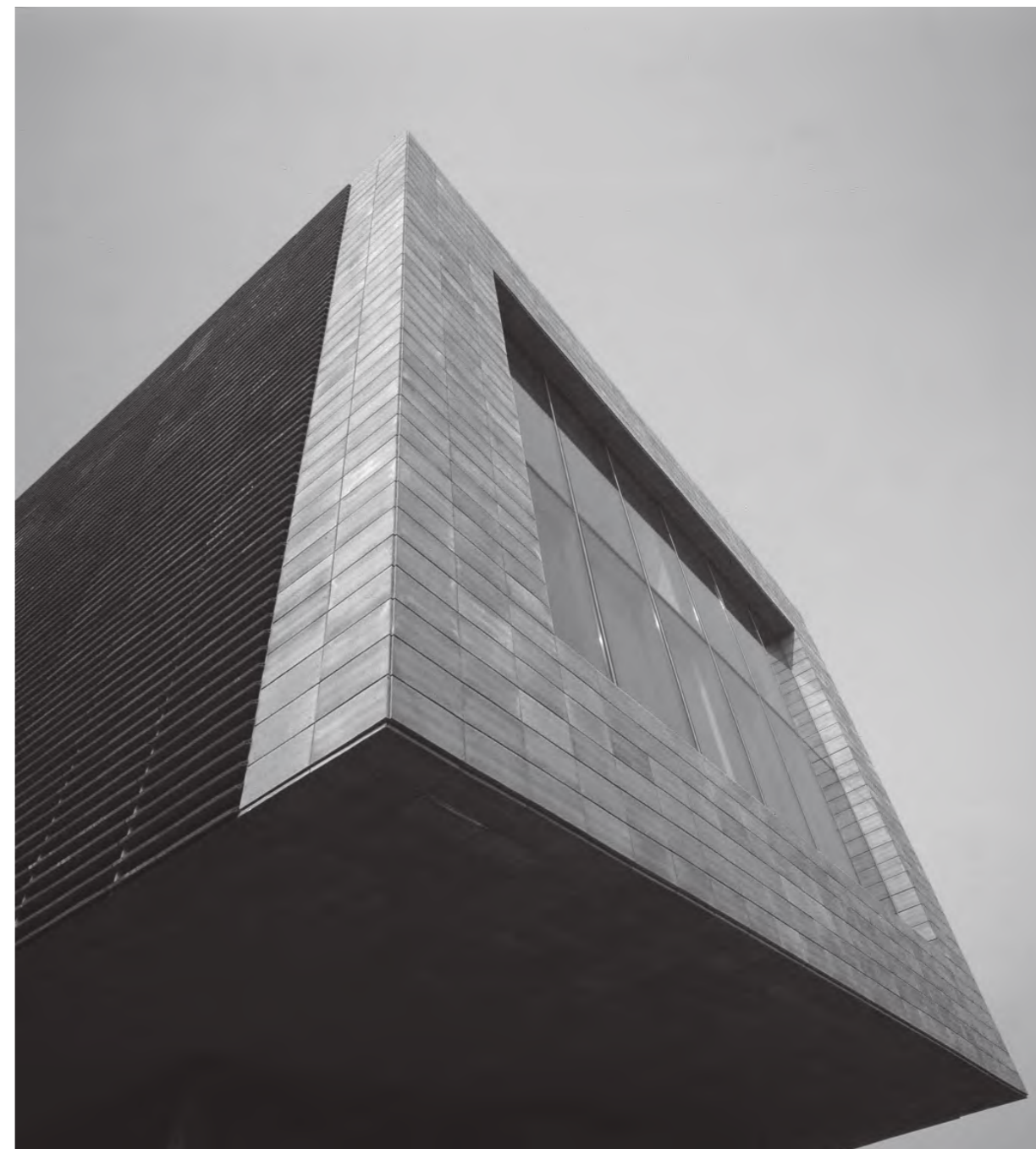

Skema project

Ai clienti che si occupano di realizzazioni particolari, progettisti e contractor, Skema offre un servizio di consulenza tecnica e progettuale oltre a una struttura commerciale dedicata che opera in tutto il territorio nazionale ed estero.

For clients engaged in special projects, designers and contractors, Skema offers technical and design consultancy, supported by a dedicated sales structure operating both nationwide and internationally.

01

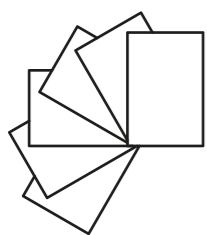

INVIO CAMPIONI
SAMPLE DELIVERY

02



ANALISI DEL PROGETTO E DELLE SOLUZIONI
PROJECT AND SOLUTION ANALYSIS

03

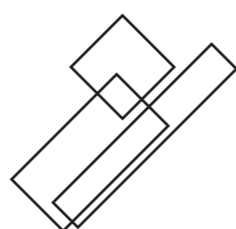

SUGGERIMENTI RELATIVI A DISPOSIZIONE E COMBINAZIONE DEI MATERIALI
RECOMMENDATIONS ON MATERIAL LAYOUT AND COMBINATIONS

04

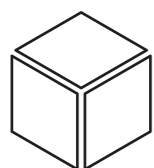

PROGETTAZIONE 3D DEI PIANI DI POSA E CALCOLO DELLE QUOTE
3D FLOOR LAYOUT DESIGN AND DIMENSIONAL CALCULATION

05

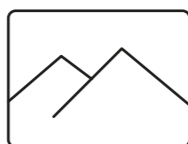

RENDER FOTOREALISTICI
PHOTOREALISTIC 3D RENDERINGS

06

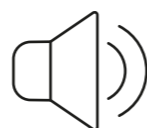

CONSULENZA ACUSTICA
ACOUSTIC CONSULTANCY

07



STESURA DEL PREVENTIVO
QUOTATION DRAFTING

08



SUPPORTO NEL PROCESSO DI ORDINE
ORDER PROCESS SUPPORT

09

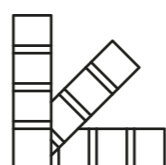

PERSONALIZZAZIONE DEL PRODOTTO
PRODUCT CUSTOMIZATION

Retail services

Negozi e rivenditori possono richiedere la progettazione di uno shop-in-shop brandizzato Skema, dotato di tutti gli strumenti per semplificare e aiutare la vendita.

Shops and retailers can request the design of a Skema branded shop-in-shop, equipped with all the tools to simplify and help sales.

01



FORNITURA DI ELEMENTI D'ARREDO
SUPPLY OF FURNISHING ELEMENTS

02

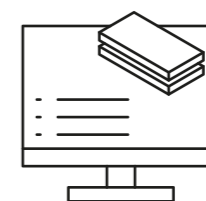

MATERIOTECA DIGITALE, SKEMATHECA, PANNELLATURE E DISPLAY
SKEMATHECA DIGITAL, MATERIAL LIBRARY, PANELS AND DISPLAYS

03

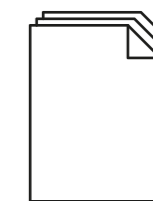

MATERIALE CARTACEO E PROMOZIONALE
PRINTED AND PROMOTIONAL MATERIAL

04

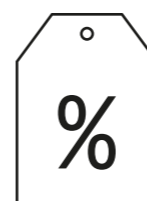

PROMOZIONI STAGIONALI SU ALCUNE LINEE DI PRODOTTO
SEASONAL PROMOTIONS ON CERTAIN PRODUCT LINES

PAVIMENTI IN LEGNO WOOD FLOORING

Ricerca estetica e valorizzazione della materia prima: i pavimenti in legno celebrano la tradizione e l'artigianalità e rispettano l'ambiente, come dimostrano le certificazioni d'origine. Alle collezioni in puro legno si affiancano quelle in legno potenziato nella resistenza, che utilizzano meno materia prima, e sono quindi ancora più sostenibili.

Aesthetic research and enhancement of the raw material: wood flooring celebrates tradition and craftsmanship and respects the environment, as proven by the certificates of origin. The pure wood collections are complemented by those in engineered wood, which use less raw material and are therefore even more sustainable.



“Il legno, con matericità e forza espressiva, diventa diretto collegamento tra architettura e natura.”

“Wood, with its materiality and expressive power, becomes a direct link between architecture and nature.”

Yles

Hexagon, Kytos, Over and Tarsia design by Franco Driusso

**La creatività ridisegna le forme,
la tradizione si trasforma
in innovazione.**

Creativity reshapes forms,
tradition transforms into
innovation.

Yles è il pavimento a moduli geometrici che reinterpreta in chiave contemporanea il tradizionale parquet, coniugando design e artigianalità. Linee e forme scandiscono superfici orizzontali e verticali, offrendo nuove prospettive per pavimenti e rivestimenti di parete. Le lavorazioni artigianali, come le spazzolature e gli effetti trama, esaltano la matericità del legno, restituendo un carattere autentico e raffinato.

I suoi punti di forza sono la grande varietà compositiva, resa possibile da nove formati e da elementi dalle forme differenti, la disponibilità di numerose collezioni e l'uso di legno tracciato e certificato, che conferma la qualità e l'origine Made in Italy del prodotto.

Yles rappresenta una vera rinascita del parquet: un pavimento che torna alle sue origini più nobili, riaffermando il legno come materia organica principe e offrendo all'interior designer infinite possibilità di progettazione.

Yles is the modular geometric flooring that reinterprets traditional parquet in a contemporary key, combining design and craftsmanship. Lines and shapes define both horizontal and vertical surfaces, offering new perspectives for floors and wall coverings. Handcrafted processes, such as brushing and textured effects, enhance the material essence of wood, giving it an authentic and refined character.

Its strengths lie in the wide compositional variety—made possible by nine formats and elements of different shapes—the availability of numerous collections, and the use of traced and certified wood, which confirms the quality and Made in Italy origin of the product. Yles represents a true renaissance of parquet: a wooden floor that returns to its most noble origins, reaffirming wood as the prime organic material and offering interior designers endless design possibilities.



Product

Yles - Folia, Natural

NEUTRA

AB

Kytos 570

Kytos 380

Kytos 190

Stylo

Folia

Hexagon

Kross

Tarsia

Tabula

Over

NATURAL

AB

Kytos 570

Kytos 380

Kytos 190

Stylo

Folia

Hexagon

Kross

Tarsia

Tabula

Over

NUX
ABC

Kytos 570
Kytos 380
Kytos 190
Stylo
Folia
Hexagon
Kross
Tarsia
Tabula
Over

FERRUM
AB

Kytos 570
Kytos 380
Kytos 190
Stylo
Folia
Hexagon
Kross
Tarsia
Tabula
Over

HARENA

AB

Kytos 570

Kytos 380

Kytos 190

Stylo

Folia

Hexagon

Kross

Tarsia

Tabula

Over

CARBO

AB

Kytos 570

Kytos 380

Kytos 190

Stylo

Folia

Hexagon

Kross

Tarsia

Tabula

Over



Product

Yles - Folia, Polvere
Yles - Tabula, Polvere

Dati tecnici
Technical data

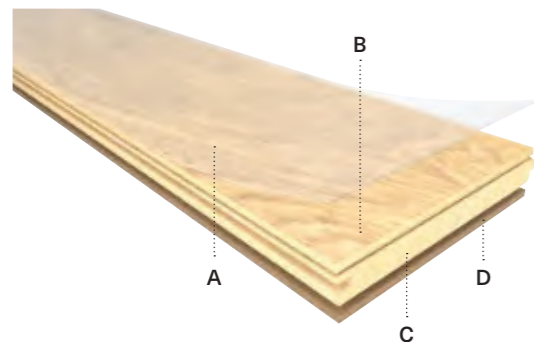

Yes

A. Finitura Olio

Oil finish

B. Legno rovere europeo o noce europeo 4 mm

European oak or european walnut wood 4 mm

C. Listellare di abete 9 mm

Fir blockboard 9 mm

D. Bilanciante in compensato di abete o derullato di pioppo 2 mm

Balancing layer in fir plywood or poplar veneer 2 mm

FORMATI/ FORMATS

Yes - Kytos 570

570x570x15/16 mm

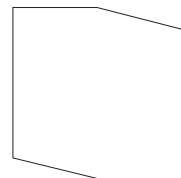

Yes - Kytos 380

855x380x15/16 mm



Yes - Kytos 190

1710x190x15/16 mm



Yes - Stylo

1080x90x15/16 mm

1800x90x15/16 mm

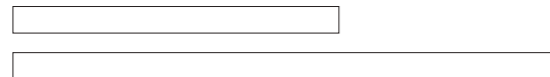

Yes - Folia

537x190x15/16 mm



Yes - Hexagon

329x190x15/16 mm



Yes - Kross

450x90x15/16 mm

540x90x15/16 mm

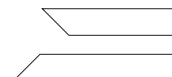

Yes - Tarsia

439x190x15/16 mm

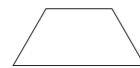

Yes - Over

540x90x15/16 mm

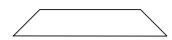

Yes - Tabula

1600>2400x190x15/16 mm



CARATTERISTICHE TECNICHE/ TECHNICAL FEATURES

Incastro

Joint



M+F/ F+F

Bisello

Bevel



4V

Reazione al fuoco*

Fire reaction*



Dfl-s1

Posa incollata in aderenza totale

Fully bonded installation



* Classificazione valida con l'utilizzo dei sottopavimenti e/o modalità indicate da Skema S.p.A. (per dettagli vedi scheda tecnica del prodotto e/o istruzioni per l'installazione).

* Classification valid with the use of underlayer and/or modality specified by Skema S.p.A. (please see product technical data sheet and/or installation instructions for details).

Elementi con incastro femmina su tutti i lati e listello maschio.
Elements with female joints on all sides and male strips.

Molteplici possibilità di posa.
Multiple installation options.

ESEMPI DI POSA/ PATTERNS EXAMPLES

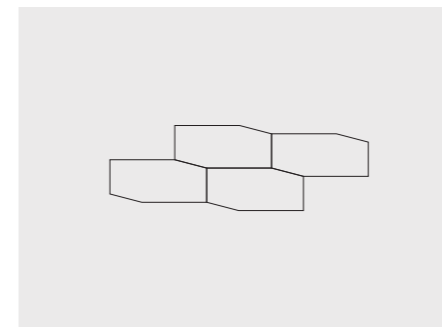

Kytos 380

855x380x15/16 mm

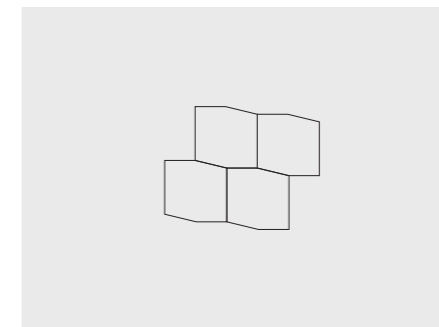

Kytos 570

570x570x15/16 mm

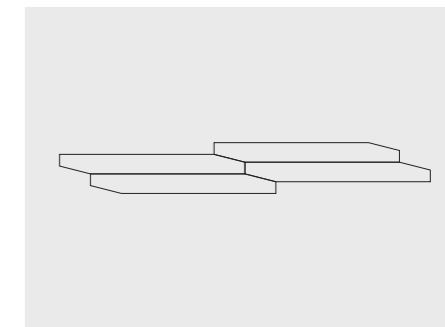

Kytos 190

1710x190x15/16 mm

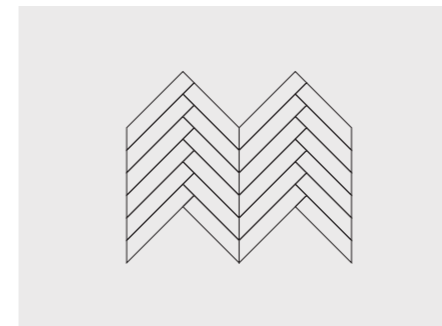

Kross

450/540x90x15/16 mm

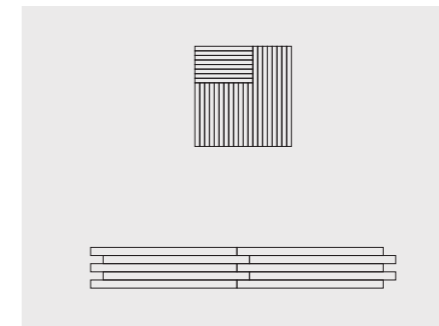

Stylo

1080/1800x90x15/16 mm

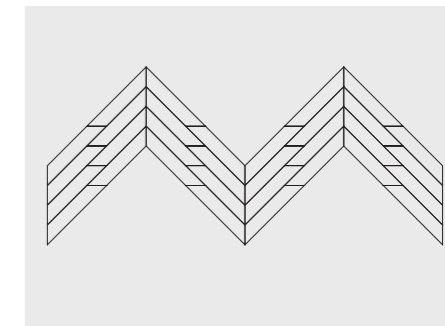

Over

540x90x15/16 mm

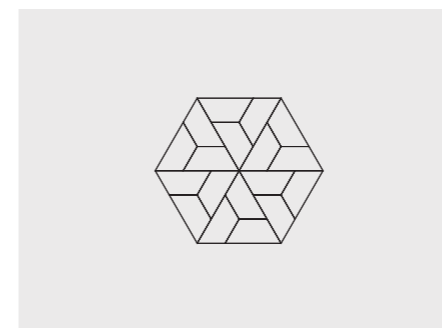

Tarsia

439/190x15/16 mm

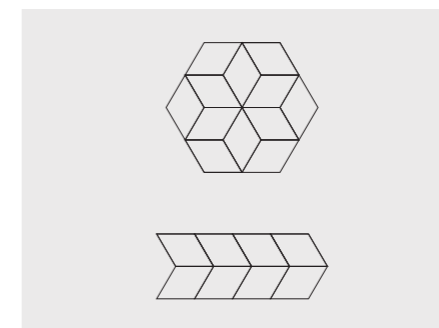

Hexagon

329x190x15/16 mm

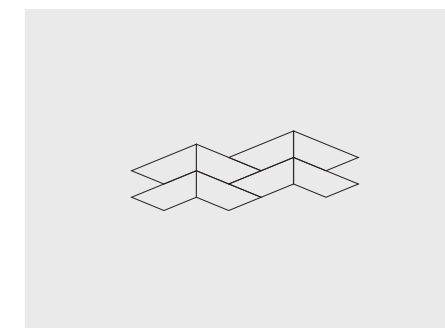

Folia

537x190x15/16 mm

Palladio

La vera natura del legno incontra l'inconfondibile eleganza dello stile italiano.

The true nature of wood meets the unmistakable elegance of Italian style.

Palladio è un pavimento in rovere di Slavonia, lavorato interamente in Italia e disponibile, su richiesta, anche in versione certificata FSC®. Proposto nei formati tavola, maxi listone e spina ungherese, unisce estetica naturale e design contemporaneo. La verniciatura opaca all'acqua e la leggera spazzolatura esaltano l'autenticità del legno, restituendo un aspetto sobrio ed elegante.

La varietà dei formati, con la versione maxi listone, l'accurata selezione, la qualità della produzione Made in Italy e la classe di reazione al fuoco Cfl-s1, che ne consente l'impiego anche in ambienti soggetti a normative specifiche sulla sicurezza, sono punti di forza inconfondibili.

Palladio è un pavimento in legno che risponde con equilibrio alle esigenze di clienti attenti alla qualità e al design, offrendo versatilità, autenticità e prestazioni tecniche ineguagliabili.

Palladio is a Slavonian oak floor, entirely crafted in Italy and, upon request, also available with FSC® certification. Offered in plank, maxi plank, and Hungarian herringbone formats, it combines natural aesthetics with contemporary design. The water-based matte finish and light brushing enhance the authenticity of the wood, delivering a refined and understated look.

Its distinctive strengths include the variety of formats, with the maxi plank option, careful selection, the quality of Italian craftsmanship, and the Cfl-s1 fire reaction rating, which makes it suitable even for environments subject to specific safety regulations.

Palladio is a wooden floor that strikes the perfect balance for clients who value quality and design, offering versatility, authenticity, and unmatched technical performance.



Product

Palladio 192 - Rovere Venezia

ROVERE VENEZIA

CL nature

1850x192x15 mm

2150x192x15 mm

2350x192x15 mm

1850x152x11 mm

2150x152x11 mm

Rovere classico, verniciato, spazzolato, tinta naturale

Classic oak, varnished, brushed, natural colour

ROVERE MASER

CL rustico

1850x192x15 mm

2150x192x15 mm

2350x192x15 mm

1850x152x11 mm

2150x152x11 mm

Rovere classico, verniciato, spazzolato, tinta naturale

Classic oak, varnished, brushed, natural colour

ROVERE TRISSINO

CL rustico

1850x192x15 mm

2150x192x15 mm

2350x192x15 mm

1850x152x11 mm

2150x152x11 mm

Rovere classico, verniciato, spazzolato, tinto crudo

Classic oak, varnished, brushed, raw coloured

ROVERE VICENZA

CL nature

1850x152x11 mm

2150x152x11 mm

Rovere classico, verniciato, spazzolato, tinto crudo

Classic oak, varnished, brushed, raw coloured

ROVERE PADOVA
CL rustico

1850x192x15 mm
2150x192x15 mm
2350x192x15 mm
1850x152x11 mm
2150x152x11 mm

Rovere classico, verniciato, taglio sega, tinta naturale
Classic oak, varnished, cutting saw, natural coloured

ROVERE MIRA
Cl rustico

1850x192x15 mm
2150x192x15 mm
2350x192x15 mm
1850x152x11 mm
2150x152x11 mm

Rovere classico, verniciato, spazzolato, smoked
Classic oak, varnished, brushed, smoked

ROVERE VICENZA

CL nature

650x120x15 mm

Rovere classico, verniciato, spazzolato, tinto crudo

Classic oak, varnished, brushed, raw coloured

Dati tecnici Technical data

STRATIGRAFIA/ STRATIGRAPHY

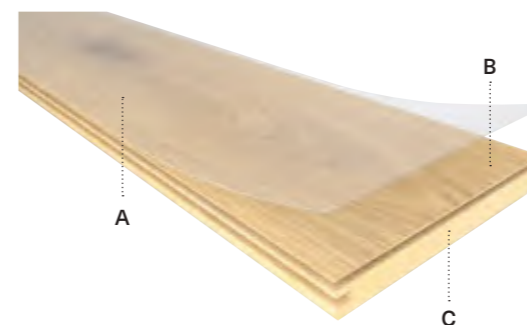

Palladio 192/ 152/ S650

- A. Vernice UV**
UV varnish
- B. Legno di rovere europeo 4 mm**
European oak 4 mm
- C. Multistrato di betulla 7-11 mm**
Birch plywood 7-11 mm

FORMATI/ FORMATS

MADE IN ITALY

Palladio 192
1850×192×15 mm
2150×192×15 mm
2350×192×15 mm



Palladio 152
1850×152×11 mm
2150×152×11 mm



Palladio S650
650×120×15 mm



CARATTERISTICHE TECNICHE/ TECHNICAL FEATURES

Incastro Joint		M+F	Posa flottante Floating installation	Palladio 192
Bisello Bevel		Micro 4v	Posa incollata in aderenza totale Fully bonded installation	Palladio 192, 152, S650
Reazione al fuoco* Fire reaction*		Cfl-s1		
Riscaldamento a pavimento Radiant heating		T ≤ 27°C		

* Classificazione valida con l'utilizzo dei sottopavimenti e/o modalità indicate da Skema S.p.A. (per dettagli vedi scheda tecnica del prodotto e/o istruzioni per l'installazione).
* Classification valid with the use of underlayer and/or modality specified by Skema S.p.A. (please see product technical data sheet and/or installation instructions for details).

ACCESSORI/ ACCESSORIES

Sottopavimenti Underlayer	Superior RBR
Profilo Profile	Kit dislivello, kit dilatazione, kit terminale, toro scala Splice kit, expansion kit, terminal kit, stair noise
Battiscopa Skirting board	W75, W45, Time, Look, Star

SPECIFICHE E CONFORMITÀ/ SPECIFICATIONS AND COMPLIANCE



* Su richiesta
* On demand

CONFEZIONAMENTO/ PACKAGING

Rif. formato/ Size	Pezzi Cfz/ Pieces Box	m ² Cfz/ Box	Cfz Pallet/ Box Pallet	m ² Pallet
1850/2150/2350×192 mm	4	VAR	50	VAR
1850/2150×152 mm	8	VAR	36	VAR
650×120 mm	10 (5dx+5sx)	0,988	28	VAR

Villa

**La tradizione del parquet
incontra lo stile contemporaneo.**
Parquet tradition meets
contemporary style.

Villa è una superficie in legno certificato che rappresenta la sintesi perfetta tra tradizione e innovazione. Ogni dogha è il risultato di un processo produttivo all'avanguardia, che garantisce massima qualità e rispetto per l'ambiente. La selezione dei materiali e la bilanciatura ottimizzata permettono di ridurre gli sprechi senza compromettere la resistenza e la bellezza del pavimento. Disponibile in quattro formati, due doghe e due spine, quattro finiture: Pisani, Tiepolo, Querini, Cornaro.

Villa has a certified wood surface that represents the perfect synthesis between tradition and innovation. Each plank is the result of a cutting-edge production process that guarantees maximum quality and respect for the environment. The selection of materials and the optimized balancing allow to reduce waste without compromising the resistance and the beauty of the floor. Available in four formats, two planks, a herringbone and a chevron, four finishings: Pisani, Tiepolo, Querini, Cornaro.



Product
Villa - Pisani, nature

PISANI
nature

2200x180x14 mm

Rovere classico, verniciato, spazzolato, tinta naturale
Classic oak, varnished, brushed, natural colour

PISANI
ambient

2200x180x14 mm
1092x130x10 mm
660x110x14 mm
550x110x14 mm

Rovere classico, verniciato, spazzolato, tinta naturale
Classic oak, varnished, brushed, natural colour

PISANI
rustic

2200x180x14 mm
1092x130x10 mm

TIEPOLO
ambient

2200x180x14 mm

Rovere classico, verniciato, spazzolato, tinta naturale
Classic oak, varnished, brushed, natural colour

Rovere classico, verniciato, spazzolato, tinta miele
Classic oak, varnished, brushed, honey colour

QUERINI
ambient

2200x180x14 mm
1092x130x10 mm
660x110x14 mm
550x110x14 mm

Rovere classico, verniciato, spazzolato, tinto crudo
Classic oak, varnished, brushed, raw coloured

CORNARO
ambient

660x110x14 mm
550x110x14 mm

Rovere classico, verniciato, spazzolato, smoked
Classic oak, varnished, brushed, smoked

CORNARO
rustic

2200x180x14 mm
1092x130x10 mm

Rovere classico, verniciato, spazzolato, smoked
Classic oak, varnished, brushed, smoked

Dati tecnici
Technical data

STRATIGRAFIA/ STRATIGRAPHY

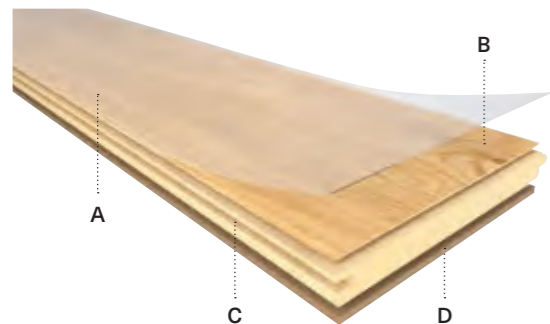

Villa 180 / H660 / C660

- A. Vernice UV
UV varnish
- B. Legno di rovere europeo 2,5 mm
European oak 2,5 mm
- C. Listellare di pino 8,5 mm
Pine blockboard 8,5 mm
- D. Piallaccio di pino 3 mm
Pine veneer 3 mm

Villa 130

- A. Vernice UV
UV varnish
- B. Legno di rovere europeo 2,5 mm
European oak 2,5 mm
- C. Listellare di pino 5 mm
Pine blockboard 5 mm
- D. Piallaccio di pino 2,5 mm
Pine veneer 2,5 mm

FORMATI/ FORMATS

Villa 180

2200x180x14 mm



Villa 130

1092x130x10 mm



Villa H660

660x110x14 mm



Villa C660

550x110x14 mm



CARATTERISTICHE TECNICHE/ TECHNICAL FEATURES

Incastro Joint		M+F	Formaldeide Formaldehyde		E1
Bisello Bevel		Micro 4v	Posa flottante Floating installation		Villa 180
Reazione al fuoco* Fire reaction*		Dfl-s1	Posa incollata in aderenza totale Fully bonded installation		Villa 180, Villa 130, H660, C660
Riscaldamento a pavimento Radiant heating		T ≤ 27°C			

* Classificazione valida con l'utilizzo dei sottopavimenti e/o modalità indicate da Skema S.p.A. (per dettagli vedi scheda tecnica del prodotto e/o istruzioni per l'installazione).
* Classification valid with the use of underlayer and/or modality specified by Skema S.p.A. (please see product technical data sheet and/or installation instructions for details).

ACCESSORI/ ACCESSORIES

Sottopavimenti Underlayer	Superior RBR
Profilo Profile	Kit dislivello, kit dilatazione, kit terminale, toro scala Splice kit, expansion kit, terminal kit, stair noise
Battiscopa Skirting board	W75, W45, Time, Look, Star

SPECIFICHE E CONFORMITÀ/ SPECIFICATIONS AND COMPLIANCE



CONFEZIONAMENTO/ PACKAGING

Rif. formato/ Size	Pezzi Cfz/ Pieces Box	m² Cfz/ Box	Cfz Pallet/ Box Pallet	m² Pallet
2200x180 mm	7	2,772	25	69,3
1092x130 mm	9	1,278	49	62,6
660x110 mm	8 (4dx+4sx)	0,581	56	32,536
550x110 mm	8 (4dx+4sx)	0,484	56	27,104

ABACO/ RECAP

Finiture Finishes	Grading	Villa 180	Villa 130	Villa H 660	Villa C660
PISANI	Nature Ambient Rustic	Ultra matt, Douglas Ultra matt, Douglas Ultra matt, Brown	- Ultra matt, Douglas Ultra matt, Brown	- Ultra matt, Douglas -	- Ultra matt, Douglas -
TIEPOLO	Ambient	Matt, Douglas	-	-	-
QUERINI	Ambient	Matt, Douglas	Matt, Douglas	-	-
CORNARO	Ambient Rustic	- Matt, Douglas	- Matt, Douglas	Matt, Douglas -	Matt, Douglas -

NATURE VILLA

Si tratta di una selezione "pulita" con piccola presenza di nodi di dimensioni contenute con limitate e morbide variazioni di fibratura e colore.
This is a "clean" selection with a small presence of small knots with limited and soft variations in grain and color.

AMBIENT VILLA

Si tratta di una selezione variegata con presenza di nodi di dimensioni piccolo/medie, sani o stuccati, caratterizzata da modeste variazioni di fibratura e colore con possibile presenza di raggi parenchimatrici (specchiature) e sporadiche sezioni di albarno.
This is a variegated selection with the presence of small/medium sized knots, healthy or filled, characterized by modest variations in grain and color with possible presence of parenchymal rays (mirroring) and sporadic sections of sapwood.

RUSTIC VILLA

Si tratta di una selezione dall'aspetto vivace con caratteristiche tipiche dei legni rustici: nodi sani e stuccati di dimensioni anche importanti, fibratura e colore piuttosto variabili, raggi parenchimatrici, sezioni di albarno e spaccature stuccate.
This is a selection with a lively appearance with typical characteristics of rustic woods: healthy and filled knots of even important size, rather variable grain and color, parenchymal rays, sapwood sections and filled cracks.

STUCCHI/ FILLERS



Stucco Douglas
Douglas Filler

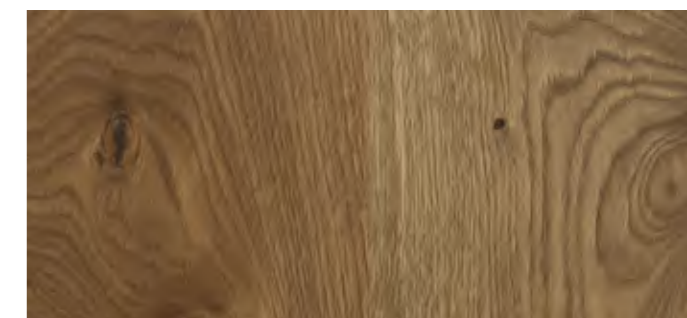

Stucco Brown
Brown Filler

Lumbertech

Il rovere si rinnova, elevata qualità e prestazioni con tecniche produttive evolute.

Oak is renewed, enhancing its quality and performance through advanced production techniques.

Lumbertech rappresenta la nuova generazione di pavimenti in legno: una superficie innovativa, certificata e sostenibile, capace di unire estetica naturale e prestazioni tecniche di alto livello. Realizzato con appena 1/8 di legno nobile rispetto a un prefinito tradizionale, ottimizza l'uso della materia prima senza rinunciare al fascino autentico del rovere. I suoi punti di forza sono la tecnologia Wood Powder, che incrementa notevolmente la resistenza al calpestio, agli urti e ai carichi concentrati, la disponibilità di diversi formati – dalle tavole alle versioni a spina – e la varietà di finiture, dalle oliate alle vernici matt a zero gloss. Le spazzolature profonde e le lavorazioni superficiali mettono in risalto le venature naturali, restituendo superfici materiche e autentiche. Certificato PEFC, superficie batteriostatica e con protezione Hydro contro la penetrazione dell'acqua nelle guarnizioni, Lumbertech è un pavimento che coniuga sostenibilità, tecnologia e design, offrendo soluzioni versatili e performanti per progetti contemporanei.

Lumbertech represents the new generation of wooden flooring: an innovative, certified, and sustainable surface that combines natural aesthetics with high-level technical performance. Made with just 1/8 of noble wood compared to traditional engineered flooring, it optimizes the use of raw materials without sacrificing the authentic charm of oak. Its strengths are the Wood Powder technology, which significantly increases resistance to trampling, impacts and concentrated loads, the availability of different formats – from planks to herringbone versions – and the variety of finishes, from oiled to zero-gloss matt varnishes. Deep brushing and surface treatments highlight the natural grain, creating tactile and authentic surfaces. PEFC certified, with a bacteriostatic surface and Hydro protection against water penetration through the seals, Lumbertech is a flooring that combines sustainability, technology and design, offering versatile and high-performance solutions for contemporary projects.

Product

Lumbertech 270 - Rovere Caspio 1439, varnish

ROVERE ADAMELLO/ 1430

CL rustic oil

2200x270x11 mm

ROVERE GRAN PARADISO/ 1431

CL rustic oil

2200x270x11 mm

ROVERE YELLOWSTONE/ 1432

CL nature oil

2200x270x11 mm

ROVERE CIRCEO/ 1434

CL rustic frame oil

2200x270x11 mm

NOCE REALE/ 1436

CL comfort oil

2200x270x11 mm

ROVERE ARENAL/ 1437

CL nature trame oil

2200x270x11 mm

ROVERE CASPIO/ 1439

CL nature varnish

2200x270x11 mm

ROVERE ONTARIO/ 1440

CL ambiente varnish

2200x270x11 mm

ROVERE POLLINO/ 1442

CL nature varnish

2200x270x11 mm

ROVERE CONERO/ 1443

CL nature varnish

2200x270x11 mm

ROVERE VALSESIA/ 1444

CL ambiente varnish

2200x270x11 mm

ROVERE BRENTA/ 1451

CL rustic varnish

2200x270x11 mm

The background of the entire page is a close-up, vertical view of a light-colored wood floor. The planks are arranged in a staggered pattern, showing natural wood grain, knots, and subtle variations in tone. The lighting is even, highlighting the texture of the wood.

ROVERE ARCHES/ 1453

CL ambiente varnish

2200x205x11 mm

ROVERE ONTARIO/ 1452

CL ambiente varnish

2200x205x11 mm

ROVERE BRENTA/ 1455

CL ambiente varnish

2200x205x11 mm

ROVERE ARCHES/ 1445

CL ambiente varnish

700x140x11 mm

ROVERE ONTARIO/ 1446

CL ambiente varnish

700x140x11 mm

ROVERE CONERO/ 1448

CL ambiente varnish

700x140x11 mm

ROVERE VALSESIA/ 1449

CL ambiente varnish

700x140x11 mm

NOCE CLASSICO/ 1450

CL ambiente varnish

700x140x11 mm

Dati tecnici Technical data

STRATIGRAFIA/ STRATIGRAPHY

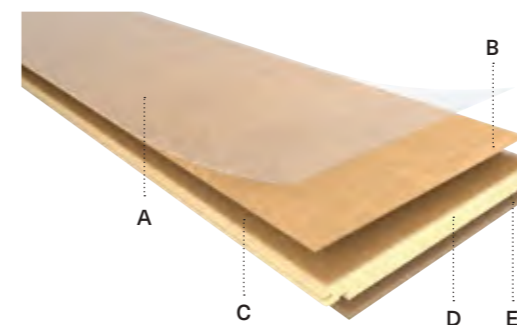

Lumbertech 270/ 205/ S700

- | | |
|--|--|
| A. Vernice UV
UV varnish | D. Pannello HDF
HDF panel |
| B. Piallaccio di vero legno
Real wood veneer | E. Bilanciante in vero legno
Balancing in real wood veneer |
| C. Polvere di legno
Wood powder | |

FORMATI/ FORMATS

Lumbertech 270

2200x270x11 mm

Lumbertech 205

2200x205x11 mm

Lumbertech S700

700x140x11 mm

CARATTERISTICHE TECNICHE/ TECHNICAL FEATURES

Incastro Joint		5G™ Dry™ (205/270)	Reazione al fuoco* Fire reaction*		Bfl-s1
Incastro Joint		PLS (S700)	Riscaldamento a pavimento Radiant heating		T ≤ 27°C
Bisello Bevel		2V (205/270)	Umidità/ resistenza all'acqua Moisture/ water resistant		(205/270)
Bisello Bevel		Micro 4v (S700)			

* Classificazione valida con l'utilizzo dei sottopavimenti e/o modalità indicate da Skema S.p.A. (per dettagli vedi scheda tecnica del prodotto e/o istruzioni per l'installazione).
* Classification valid with the use of underlayer and/or modality specified by Skema S.p.A. (please see product technical data sheet and/or installation instructions for details).

** Disponibile con incastro TLS fino ad esaurimento scorte.
** Available with TLS joint while stocks last.

Lumbertech esprime il meglio di sé quale pavimento flottante abbinato al materassino Superior RBR, ma grazie alla tecnologia di costruzione Wood Powder può essere posato anche in aderenza totale con colla. È fondamentale tener conto delle indicazioni del protocollo di incollaggio Skema. Vedi QRcode.
Lumbertech expresses itself at its best as a floating floor combined with Superior RBR matting, but thanks to the Wood Powder construction technology it can also be laid in full adhesion with glue. It is essential to take into account the information in the Skema bonding protocol. See QRcode.



ACCESSORI/ ACCESSORIES

Sottopavimenti Underlayer	Superior RBR, DB
Profilo Profile	Kit dislivello, kit terminale, profilo scala Expansion kit, terminal kit, stair profile
Battiscopa Skirting board	Star, Look, Time

SPECIFICHE E CONFORMITÀ/ SPECIFICATIONS AND COMPLIANCE



* Solo per Lumbertech 205 e 270
* Only for Lumbertech 205 e 270

CONFEZIONAMENTO/ PACKAGING

Rif. formato/ Size	Pezzi Cfz/ Pieces Box	m² Cfz/ Box	Cfz Pallet/ Box Pallet	m² Pallet
2200x270 mm	4	2,376	30	71,28
2200x205 mm	4	1,804	40	72,16
700x140 mm	10	0,980	56	54,88

PAVIMENTI IN LEGNO/ WOOD FLOORING

PROGRAMMA LIVE
LIVE PROGRAM

Pavimenti in legno personalizzati

Customized wood flooring

Il programma Live nasce per offrire la massima personalizzazione nella scelta di lavorazioni, finiture e colori, ampliando le possibilità dei pavimenti in legno Made in Italy. Le soluzioni disponibili includono doghe e spine (italiana e francese) con struttura a 2 o 3 strati, in diverse larghezze e lunghezze, in base alle disponibilità di magazzino. I nostri team Customer Care e Project Management sono a disposizione per supportare richieste specifiche e fornire campionature per l'approvazione della produzione.

The Live program was created to offer maximum customization in the selection of processes, finishes, and colours, expanding the creative possibilities of Made in Italy wood flooring. Available options include planks and herringbone or chevron patterns with 2- or 3-layer construction, offered in various widths and lengths according to stock availability. Our Customer Care and Project Management teams are available to assist with specific requests and provide samples for production approval.

Step 1: Lavorazioni

Step 1: Processing

SPAZZOLATO BRUSHING



Lavorazione artigianale che conferisce alla tavola un gradevole aspetto segnato dal tempo.

Handcrafted process that gives the planks a pleasantly time-worn look.

PIALLATO HAND-SCRAPING

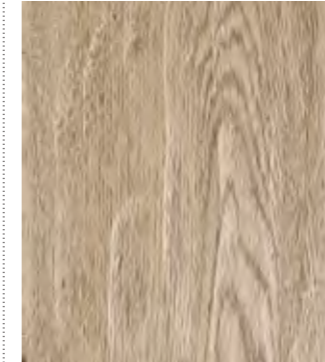

Lavorazione artigianale rigorosamente fatta a mano doga per doga; la tavola viene "scalpita" anche contro vena per far risaltare maggiormente le caratteristiche del legno.

Each plank is meticulously handcrafted and even worked against the grain to highlight the natural character of the wood.

TAGLIO SEGA SAWING



Lavorazione artigianale che produce dei tagli trasversali importanti sulla tavola, rendendola "vissuta".

Handcrafted process that creates deep transverse cuts on the planks, giving them a beautifully weathered look.

TRAME TEXTURING



Lavorazione effetto trame, che riproduce una seghetatura dolce e non invasiva, simile alla texture del tessuto in garza.

A handcrafted finish with delicate saw marks that create a subtle texture, reminiscent of gauze fabric.

Step 2: Trattamenti

Step 2: Treatments

OSSIDATO OXIDATED



Tecnica naturale che avviene per reazione della materia eseguita in autoclave o per impregnazione e che dona un effetto invecchiato al legno.

A natural process that takes place through the material's own reaction, carried out in an autoclave or by impregnation, giving the wood an aged appearance.

OLIATO OILED

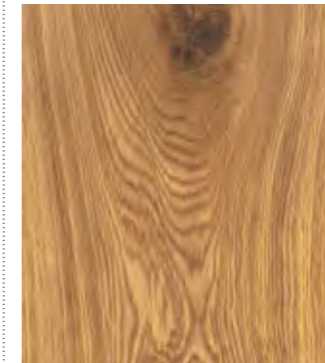

Finitura che prevede l'applicazione di olii naturali sulla superficie del legno, si distingue per la naturalezza del colore che il parquet assume mettendo in risalto venature e tonalità del legno.

A finish obtained by applying natural oils to the wood surface, enhancing its grain and tones while preserving the wood's natural colour.

VERNICIATO VARNISHING



Finitura eseguita applicando un film superficiale di vernice che protegge il legno dalle sollecitazioni meccaniche e chimiche, rendendolo più resistente e più facile da pulire.

A finish created by applying a surface layer of varnish that protects the wood from mechanical and chemical stress, making it more durable and easier to clean.

PAVIMENTI TECNICI TECHNICAL FLOORING

I pavimenti tecnici rappresentano, storicamente, il cuore della proposta di Skema e continuano a essere la scelta migliore in molti contesti per le loro caratteristiche tecniche e il loro realismo.

Ampia la scelta di decori, dall'effetto legno al materico, e di formati, dalla dogia al tile.

L'estetica è ricercata grazie al sincroporo, che riproduce fedelmente le venature del legno, e alla superficie opaca e altamente performante.

I pavimenti tecnici sono antistatici e compatibili con il riscaldamento a pavimento.

Technical flooring have historically been the core of Skema's offer and continue to be the best choice in many contexts for their technical characteristics and realistic appearance.

There is a wide choice of patterns, from wood effect to material, and of formats, from planks to tiles.

Aesthetics are sought after thanks to the syncropore technology, which faithfully reproduces the wood grain, and the matte, high-performance surface.

Technical floors are antistatic and compatible with underfloor heating.



“Una superficie che unisce tecnica ed estetica in un equilibrio naturale. La sintesi perfetta di solidità, durevolezza e forza espressiva.”

“A surface that blends technology and aesthetics in a natural balance. The perfect synthesis of strength, durability, and expressive character.”

K-Uno

Tecnologia e gusto danno vita a una superficie resistente ed evocativa.

Technology and style give life to a surface that is both durable and evocative.

K-Uno rappresenta il top di gamma nel mondo dei pavimenti tecnici Skema, un prodotto che unisce elevate performance tecniche a un'estetica sorprendentemente realistica. Il suo punto di forza è l'integrazione della tecnologia Hydro, che garantisce una protezione efficace contro i ristagni d'acqua, rendendo K-Uno ideale anche per ambienti umidi o soggetti a frequente pulizia.

La doga, dal grande formato (2052x248x10 mm), valorizza al massimo l'effetto materico e la resa visiva del legno naturale. La superficie è trattata con tecnologia sincroporo che riproduce fedelmente le venature e la texture del legno, offrendo un effetto ultra realistico al tatto e alla vista.

Un ulteriore elemento distintivo è la microbisellatura su tutti e quattro i lati, trattata con lo speciale componente Sigil joint, che la rende totalmente protetta dall'umidità e ne preserva la durabilità nel tempo.

Il sistema di posa è affidato al moderno incastro 5G™ Dry™, che combina rapidità e semplicità di installazione con un'elevata tenuta stagna, assicurando massima stabilità e protezione del pavimento anche nelle condizioni più critiche.

Con K-Uno, estetica e tecnologia si fondono in un pavimento tecnico che interpreta al meglio le esigenze dell'abitare contemporaneo, con prestazioni evolute e un design naturale che conquista al primo sguardo.

K-Uno represents the top of the range of Skema technical flooring, a product that combines outstanding technical performance with a surprisingly realistic aesthetic. Its key strength lies in the integration of Hydro technology, which provides effective protection against standing water, making K-Uno ideal even for humid environments or areas subject to frequent cleaning.

The large-format plank (2052x248x10 mm) maximizes the tactile and visual impact of natural wood.

The surface is treated with synchronized embossing technology, which faithfully reproduces wood grain and texture, delivering an ultra-realistic effect to both sight and touch.

Another distinctive element is the four-sided micro-bevel, treated with the special Sigil joint component, ensuring complete protection against moisture and preserving long-term durability. Installation is made simple and secure with the advanced 5G™ Dry™ locking system, which combines speed and ease of laying with exceptional watertight sealing, guaranteeing maximum stability and floor protection even under the most demanding conditions.

With K-Uno, aesthetics and technology merge in a technical flooring that perfectly interprets the needs of contemporary living, offering advanced performance and a natural design that captivates at first glance.

Product

K-Uno - Rovere Colorado 531

ROVERE INDIANA/ 520

emotion

2052x248x10 mm

ROVERE LATINO/ 527

emotion

2052x248x10 mm

ROVERE TEXAS/ 528

emotion

2052x248x10 mm

ROVERE ARIZONA/ 530

emotion

2052x248x10 mm

ROVERE COLORADO/ 531

emotion

2052x248x10 mm

ROVERE MEXICO/ 532

emotion

2052x248x10 mm

ROVERE YOSEMITE/ 533

emotion

2052x248x10 mm

ROVERE KANSAS/ 534

emotion

2052x248x10 mm

ROVERE CALIFORNIA NEW/ 535

emotion

2052x248x10 mm



Dati tecnici Technical data

STRATIGRAFIA/ STRATIGRAPHY

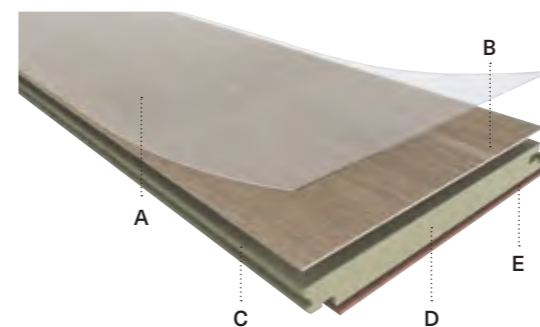









- A. Superficie High Wear**
High Wear surface
- B. Carta decorativa antistatica**
Antistatic decorative paper
- C. Strato intermedio HDF trattato**
Treated HDF intermediate layer
- D. Bordi trattati con Sigil joint**
Edges treated with Sigil joint
- E. Controbilanciante**
Balancing layer

FORMATI/ FORMATS

K-uno
2052x248x10 mm



CARATTERISTICHE TECNICHE/ TECHNICAL FEATURES

Incastro Joint		5G™ Dry™	Umidità/ resistenza all'acqua Moisture/ water resistant	
Bisello Bevel		4V	Uso domestico Domestic use	 23 Alto Traffico High Traffic
Reazione al fuoco* Fire reaction*		Cfl-s1	Uso commerciale Commercial use	 32 Medio Traffico Medium Traffic
Riscaldamento a pavimento Radiant heating		T ≤ 27°C	Classe di abrasione Abrasion class	AC4
Antistatico Antistatic				

* Classificazione valida con l'utilizzo dei sottopavimenti e/o modalità indicate da Skema S.p.A. (per dettagli vedi scheda tecnica del prodotto e/o istruzioni per l'installazione).
* Classification valid with the use of underlayer and/or modality specified by Skema S.p.A. (please see product technical data sheet and/or installation instructions for details).

ACCESSORI/ ACCESSORIES

Sottopavimenti Underlayer	Superior RBR, DB, ST
Profilo Profile	Kit dislivello, kit dilatazione, kit terminale, toro scala Elite Splice kit, expansion kit, terminal kit, Elite stair nosing
Battiscopa Skirting board	Drop

SPECIFICHE E CONFORMITÀ/ SPECIFICATIONS AND COMPLIANCE



CONFEZIONAMENTO/ PACKAGING

Rif. formato/ Size	Pezzi Cfz/ Pieces Box	m ² Cfz/ Box	Cfz Pallet/ Box Pallet	m ² Pallet
2052x248 mm	4	2,035	42	85,494

Prestige Gold

Una superficie tecnica pensata per raggiungere l'autenticità della natura.

A technical surface designed to restore naturalness in all its perfection.

Prestige Gold rappresenta una delle collezioni più consolidate e apprezzate del mondo Skema, un pavimento tecnico che ha saputo evolversi negli anni fino a diventare un vero punto di riferimento per chi cerca un pavimento resistente e di grande realismo.

Il suo punto di forza è la combinazione tra un'estetica naturale, capace di spaziare dallo stile rustico al contemporaneo, e performance tecniche potenziate che lo rendono adatto sia all'uso abitativo sia agli spazi pubblici e commerciali ad alta frequentazione.

Le doghe, con microbisellatura sui quattro lati, sono trattate con tecnologia sincroporo, che riproduce fedelmente venature e texture naturali, offrendo un effetto ultra realistico alla vista e al tatto.

Sul piano tecnico, oggi Prestige Gold si connota per le notevoli performance tecniche potenziate, grazie all'acquisizione della tecnologia Hydro, al salto di classe nella resistenza all'abrasione che passa ad AC5 e nuovo incastro PLS, che combina velocità e semplicità d'installazione con una stabilità duratura, garantendo la massima affidabilità in ogni condizione.

Con Prestige Gold estetica e tecnologia si fondono in un pavimento tecnico versatile e performante, pensato per soddisfare le esigenze dell'abitare contemporaneo e per resistere nel tempo con stile ed efficienza.

Prestige Gold represents one of the most established and appreciated collections in the Skema world, a technical flooring that has evolved over the years to become a true benchmark for those seeking a floor that is both durable and remarkably realistic.

Its strength lies in the combination of a natural aesthetic, ranging from rustic to contemporary styles, and enhanced technical performance, making it suitable for both residential use and high-traffic public and commercial spaces.

The planks, with four-sided micro-bevels, are treated with synchronized embossing technology, which faithfully reproduces natural wood grains and textures, delivering an ultra-realistic effect to both sight and touch.

On the technical side, Prestige Gold now stands out for its upgraded performance, thanks to Hydro technology, the step up to AC5 abrasion resistance, and the new PLS locking system, which combines speed and ease of installation with long-lasting stability, ensuring maximum reliability under all conditions.

With Prestige Gold, aesthetics and technology merge into a versatile, high-performance technical flooring, designed to meet the needs of contemporary living and to stand the test of time with style and efficiency.



Product

Prestige Gold - Quercia Montana 257

ROVERE SOLE/ 139

emotion

1288x198x8 mm

ROVERE ZEPHIR/ 170

emotion

1288x198x8 mm

ROVERE GIAPPONESE/ 255

emotion

1288x198x8 mm

ROVERE TRENINO/ 256

emotion

1288x198x8 mm

* **Disponibile fino ad esaurimento scorte**

* Available while supplies last

QUERCIA MONTANA/ 257
emotion

1288x198x8 mm

ROVERE CARBON/ 258
emotion

1288x198x8 mm

ROVERE COMFORT/ 259

emotion

1288x198x8 mm

QUERCIA NATURALE/ 264

emotion

1288x198x8 mm

ROVERE POSITANO/ 266

emotion

1288x198x8 mm

HOP OAK/ 279

emotion

1288x198x8 mm

ROVERE FRANCESE / 289

emotion

1288x198x8 mm

ROVERE PONZA NEW / 293

emotion

1288x198x8 mm

ROVERE LINOSA NEW/ 294

emotion

1288x198x8 mm

SESAME OAK/ 370

emotion

1288x198x8 mm

PEPPER OAK/ 372

emotion

1288x198x8 mm



Dati tecnici Technical data

STRATIGRAFIA/ STRATIGRAPHY

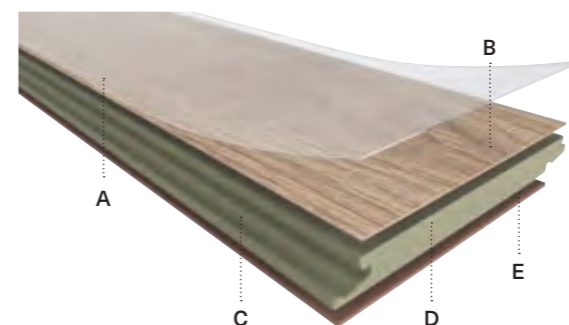



- A. Superficie High Wear**
High Wear surface
- B. Carta decorativa antistatica**
Antistatic decorative paper
- C. Strato intermedio HDF trattato**
Treated HDF intermediate layer
- D. Bordi trattati con Sigil joint**
Edges treated with Sigil joint
- E. Controilanciante**
Balancing layer

FORMATI/ FORMATS

Prestige Gold
1288x198x8 mm



CARATTERISTICHE TECNICHE/ TECHNICAL FEATURES

Incastro Joint		PLS	Umidità/ resistenza all'acqua Moisture/ water resistant	
Bisello Bevel		4V	Uso domestico Domestic use	 23 Alto Traffico High Traffic
Reazione al fuoco* Fire reaction*		Cfl-s1	Uso commerciale Commercial use	 32 Medio Traffico Medium Traffic
Riscaldamento a pavimento Radiant heating		T ≤ 27°C	Classe di abrasione Abrasion class	AC5
Antistatico Antistatic				

* Classificazione valida con l'utilizzo dei sottopavimenti e/o modalità indicate da Skema S.p.A. (per dettagli vedi scheda tecnica del prodotto e/o istruzioni per l'installazione).
* Classification valid with the use of underlayer and/or modality specified by Skema S.p.A. (please see product technical data sheet and/or installation instructions for details).

ACCESSORI/ ACCESSORIES

Sottopavimenti Underlayer	Superior RBR, DB, ST
Profilo Profile	Kit dislivello, kit dilatazione, kit terminale, toro scala Elite Splice kit, expansion kit, terminal kit, Elite stair nosing
Battiscopa Skirting board	Time, Look

SPECIFICHE E CONFORMITÀ/ SPECIFICATIONS AND COMPLIANCE



CONFEZIONAMENTO/ PACKAGING

Rif. formato/ Size	Pezzi Cfz/ Pieces Box	m ² Cfz/ Box	Cfz Pallet/ Box Pallet	m ² Pallet
1288x198 mm	10	2,550	40	102,010

PAVIMENTI TECNICI/ TECHNICAL FLOORING

Prestige L

Le suggestioni del grande formato stimolano la creatività.
The allure of large formats inspires creativity.

Prestige L rappresenta uno dei pavimenti tecnici più iconici della gamma Skema. Ha tutte le qualità che lo rendono apprezzato dal mercato: superficie antistatica, bordi bisellati sui quattro lati e resa estetica naturale garantita dalla tecnologia sincroporo, che riproduce con fedeltà le venature del legno donando un realismo percepibile sia alla vista che al tatto. Oggi Prestige L si rinnova con l'introduzione della tecnologia Hydro, che incrementa la resistenza all'acqua, e con il nuovo incastro 5G™ Dry™ a tenuta stagna, capace di impedire l'infiltrazione di liquidi attraverso i profili. Completano il quadro i nuovi decorativi con effetto zero gloss, che arricchiscono l'offerta estetica con superfici dal fascino contemporaneo. Compatibile con il riscaldamento a pavimento, Prestige L garantisce ottima conducibilità termica e stabilità nel tempo. Con la sua combinazione di formato imponente (2052x2220 mm), estetica realistica e performance potenziate, Prestige L è un grande classico che continua a definire standard elevati nel mondo dei pavimenti tecnici.

Prestige L represents one of the most iconic technical flooring in the Skema range. It embodies all the qualities that have made it highly appreciated in the market: an antistatic surface, four-sided beveled edges, and a natural look ensured by synchronized embossing technology, which faithfully reproduces wood grain for realism perceivable both visually and to the touch. Today, Prestige L is renewed with the introduction of Hydro technology, which increases water resistance, and the new 5G™ Dry™ watertight locking system, designed to prevent liquid infiltration through the joints. Completing the range are new zero-gloss décors, which enrich the aesthetic offering with surfaces of contemporary appeal. Compatible with underfloor heating, Prestige L ensures excellent thermal conductivity and long-term stability. With its combination of imposing format (2052x2220 mm), realistic aesthetics, and enhanced performance, Prestige L remains a great classic that continues to set high standards in the world of technical flooring.



Product
Prestige L - Grey Oak 168

GREY OAK/ 168

natural

2052x220x8 mm

NOCE AUTENTICO/ 178

modern

2052x220x8 mm

ROVERE APPLE / 234

natural

2052x220x8 mm

ROVERE SENESE / 250

natural

2052x220x8 mm

ALPACA OAK/ 290
emotion

2052x220x8 mm

EAGLE OAK/ 291
natural

2052x220x8 mm

PEPPER OAK/ 372

emotion

2052x220x8 mm



Dati tecnici Technical data

STRATIGRAFIA/ STRATIGRAPHY

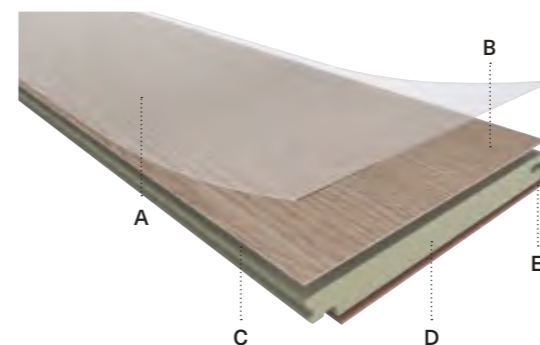









- A. Superficie High Wear**
High Wear surface
- B. Carta decorativa antistatica**
Antistatic decorative paper
- C. Strato intermedio HDF trattato**
Treated HDF intermediate layer
- D. Bordi trattati con Sigil joint**
Edges treated with Sigil joint
- E. Controilanciante**
Balancing layer

FORMATI/ FORMATS

Prestige L
2052x220x8 mm



CARATTERISTICHE TECNICHE/ TECHNICAL FEATURES

Incastro Joint		5G™ Dry™	Umidità/ resistenza all'acqua Moisture/ water resistant	
Bisello Bevel		4V	Uso domestico Domestic use	 23 Alto Traffico High Traffic
Reazione al fuoco* Fire reaction*		Cfl-s1	Uso commerciale Commercial use	 32 Medio Traffico Medium Traffic
Riscaldamento a pavimento Radiant heating		T ≤ 27°C	Classe di abrasione Abrasion class	
Antistatico Antistatic				

* Classificazione valida con l'utilizzo dei sottopavimenti e/o modalità indicate da Skema S.p.A. (per dettagli vedi scheda tecnica del prodotto e/o istruzioni per l'installazione).
* Classification valid with the use of underlayer and/or modality specified by Skema S.p.A. (please see product technical data sheet and/or installation instructions for details).

ACCESSORI/ ACCESSORIES

Sottopavimenti Underlayer	Superior RBR, DB, ST
Profilo Profile	Kit dislivello, kit dilatazione, kit terminale, toro scala Elite Splice kit, expansion kit, terminal kit, Elite stair nosing
Battiscopa Skirting board	Time, Look

SPECIFICHE E CONFORMITÀ/ SPECIFICATIONS AND COMPLIANCE



CONFEZIONAMENTO/ PACKAGING

Rif. formato/ Size	Pezzi Cfz/ Pieces Box	m ² Cfz/ Box	Cfz Pallet/ Box Pallet	m ² Pallet
2052x220 mm	6	2,708	36	97,511

PAVIMENTI TECNICI/ TECHNICAL FLOORING

Facile+

Design contemporaneo e facilità di posa, la soluzione ideale per ristrutturazioni smart.

Contemporary design and easy installation, the ideal solution for smart renovations.

Facile+ è una collezione sempre attuale, pensata per chi desidera trasformare rapidamente l'aspetto di una casa, di un hotel o di un negozio grazie a interventi di ristrutturazione veloci ed efficaci.

È un pavimento elegante e pratico da posare, che si distingue per l'assenza di bisellatura e per la varietà di decorativi, sempre più ampia e in linea con le tendenze contemporanee.

I suoi punti di forza sono la posa semplificata con tecnologia d'incastro PLS, la resistenza ai ristagni d'acqua ottenuta grazie all'applicazione delle ultime tecnologie Skema e la proposta di ben 17 decori effetto legno naturale, in grado di dare carattere e personalità a ogni ambiente.

Versatile e affidabile, Facile+ è il pavimento tecnico che semplifica ogni progetto, risultando ideale sia per ristrutturazioni sia per nuove realizzazioni.

Facile+ is a timeless collection designed for those who wish to quickly transform the look of a home, hotel, or shop through fast and effective renovations.

It is an elegant and easy-to-install flooring, distinguished by its absence of beveling and a wide variety of décors, constantly expanding and aligned with contemporary trends.

Its strengths include simplified installation with PLS locking technology, resistance to standing water thanks to the latest Skema innovations, and a choice of 17 natural wood-effect décors, capable of giving character and personality to any space.

Versatile and reliable, Facile+ is the technical flooring that makes every project easier, making it the ideal solution both for renovations and for new constructions.



Product

Facile+ - Rovere Crystal 167

WHITE WOOD/ 127

natural

1288x198x8 mm

ROVERE SUPERIOR/ 128

timber

1288x198x8 mm

ROVERE SUNNY/ 166

natural

1288x198x8 mm

ROVERE CRYSTAL/ 167

natural

1288x198x8 mm

* Stonalizzato

* Shade-varied

GREY OAK/ 168
natural

1288x198x8 mm

ROVERE LUNA/ 192
natural

1288x198x8 mm

* Stonalizzato
* Shade-varied

ROVERE UMBRO/ 196

natural

1288x198x8 mm

ROVERE LOIRA/ 242

natural

1288x198x8 mm

ROVERE SENESE / 250
natural

1288x198x8 mm

ROVERE FIAMMINGO / 252
timber

1288x198x8 mm

ROVERE DI FIUME / 253

emotion

1288x198x8 mm

ROVERE TUSCANIA / 254

emotion

1288x198x8 mm

GREY CANYON/ 260
natural

1288x198x8 mm

BLACK CANYON/ 262
natural

1288x198x8 mm

* **Disponibile fino ad esaurimento scorte**
* Available while supplies last

* **Disponibile fino ad esaurimento scorte**
* Available while supplies last

HOP OAK/ 279
emotion

1288x198x8 mm

COFFEE OAK/ 280
natural

1288x198x8 mm

Dati tecnici Technical data

STRATIGRAFIA/ STRATIGRAPHY

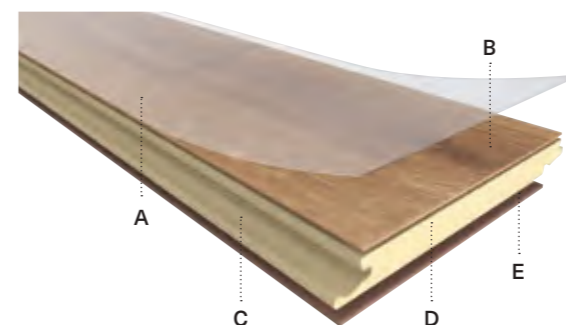







- A. Superficie High Wear**
High Wear surface
- B. Carta decorativa antistatica**
Antistatic decorative paper
- C. Strato intermedio HDF trattato**
Treated HDF intermediate layer
- D. Bordi trattati con Sigil joint**
Edges treated with Sigil joint
- E. Controilanciante**
Balancing layer

FORMATI/ FORMATS

Facile+
1288x198x8 mm



CARATTERISTICHE TECNICHE/ TECHNICAL FEATURES

Incastro Joint		PLS	Uso domestico Domestic use		23 Alto Traffico High Traffic
Bisello Bevel		No	Uso commerciale Commercial use		32 Medio Traffico Medium Traffic
Reazione al fuoco* Fire reaction*		Cfl-s1	Classe di abrasione Abrasion class	AC4	
Riscaldamento a pavimento Radiant heating		T ≤ 27°C			
Antistatico Antistatic					

* Classificazione valida con l'utilizzo dei sottopavimenti e/o modalità indicate da Skema S.p.A. (per dettagli vedi scheda tecnica del prodotto e/o istruzioni per l'installazione).
* Classification valid with the use of underlayer and/or modality specified by Skema S.p.A. (please see product technical data sheet and/or installation instructions for details).

ACCESSORI/ ACCESSORIES

Sottopavimenti Underlayer	Superior RBR, DB, ST
Profilo Profile	Kit dislivello, kit dilatazione, kit terminale Splice kit, expansion kit, terminal kit
Battiscopa Skirting board	Star, Time trendy, Look trendy

SPECIFICHE E CONFORMITÀ/ SPECIFICATIONS AND COMPLIANCE



CONFEZIONAMENTO/ PACKAGING

Rif. formato/ Size	Pezzi Cfz/ Pieces Box	m ² Cfz/ Box	Cfz Pallet/ Box Pallet	m ² Pallet
1288x198 mm	10	2,550	40	102,010

Syncro Parquet

**La spina in pavimento tecnico,
dove la tradizione incontra
l'innovazione.**

The herringbone in technical
flooring, where tradition meets
innovation.

Syncro Parquet reinterpreta l'eleganza intramontabile della posa a spina di pesce, unendo il fascino della tradizione alla praticità delle soluzioni Skema.

Disponibile sia nella versione classica sia in quella ungherese con taglio inclinato, permette un'installazione rapida e precisa grazie al sistema d'incastro PLS.

I suoi punti di forza sono la protezione dall'acqua garantita dalla tecnologia Hydro Plus, lo spessore ottimizzato di 8 mm, la massima resistenza all'abrasione AC6 e la classe di reazione al fuoco Bfl-s1, che lo rendono adatto anche ad ambienti ad alto traffico come hotel, ristoranti e scuole.

Syncro Parquet combina performance tecniche di livello superiore con il pregio estetico della spina di pesce, offrendo un pavimento raffinato e resistente.

Syncro Parquet reinterprets the timeless elegance of the herringbone pattern, combining the charm of tradition with the practicality of Skema solutions.

Available in both the classic version and the Hungarian cut with angled edges, it allows quick and precise installation thanks to the PLS locking system.

Its strengths include water protection ensured by Hydro Plus technology, an optimized thickness of 8 mm, maximum abrasion resistance AC6, and a Bfl-s1 fire reaction rating, making it suitable even for high-traffic environments such as hotels, restaurants, and schools.

Syncro Parquet combines superior technical performance with the refined aesthetics of herringbone, offering a floor that is both elegant and durable.



Product

Syncro Parquet - Ungherese 1151, rovere naturale

CLASSICA/ 1150
rovere naturale

1182x293x8 mm

UNGHERESE/ 1151
rovere naturale

1184x293x8 mm

CHATEAU/ 1164

rovere naturale

1183x601x8 mm



Dati tecnici Technical data

STRATIGRAFIA/ STRATIGRAPHY

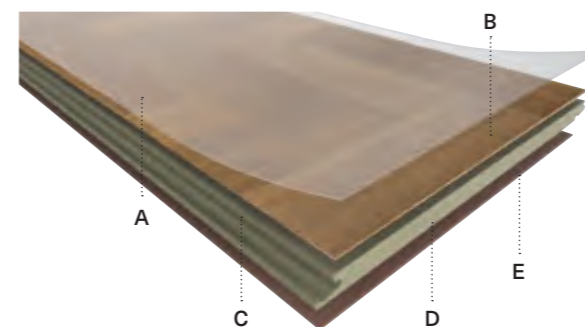

- A. Superficie High Wear**
High Wear surface
- B. Carta decorativa antistatica**
Antistatic decorative paper
- C. Strato intermedio HDF trattato**
Treated HDF intermediate layer
- D. Bordi trattati con Sigil joint**
Edges treated with Sigil joint
- E. Controilanciante**
Balancing layer

FORMATI/ FORMATS

Syncro Parquet - Classica
1182x293x8 mm

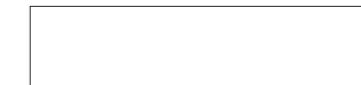

Syncro Parquet - Ungherese
1184x293x8 mm



Syncro Parquet - Chateau
1183x601x8 mm



CARATTERISTICHE TECNICHE/ TECHNICAL FEATURES

Incastro Joint		PLS (Classica, Ungherese)	Antistatico Antistatic	
		TLS.PF (Chateau)	Umidità/ resistenza all'acqua Moisture/ water resistant	
Bisello Bevel		Sincro bisello stampato sui 4 lati Syncro bevel printed on the 4 sides	Uso domestico Domestic use	 23 Alto Traffico High Traffic
Reazione al fuoco* Fire reaction*		Bfl-s1	Uso commerciale Commercial use	 33 Alto Traffico High Traffic
Riscaldamento a pavimento Radiant heating		T ≤ 27°C	Classe di abrasione Abrasion class	AC6

* Classificazione valida con l'utilizzo dei sottopavimenti e/o modalità indicate da Skema S.p.A. (per dettagli vedi scheda tecnica del prodotto e/o istruzioni per l'installazione).
* Classification valid with the use of underlayer and/or modality specified by Skema S.p.A. (please see product technical data sheet and/or installation instructions for details).

ACCESSORI/ ACCESSORIES

Sottopavimenti Underlayer	Superior RBR, DB, ST
Profilo Profile	Kit dislivello, kit dilatazione, kit terminale Splice kit, expansion kit, terminal kit
Battiscopa Skirting board	Star, Time, Look

SPECIFICHE E CONFORMITÀ/ SPECIFICATIONS AND COMPLIANCE



CONFEZIONAMENTO/ PACKAGING

Rif. formato/ Size	Pezzi C fz/ Pieces Box	m ² C fz/ Box	C fz Pallet/ Box Pallet	m ² Pallet
1184x293 mm	6	2,081	51	106,30
1182x293 mm	6	2,078	51	106,02
1183x601 mm	3	2,133	68	145,40

PAVIMENTI TECNICI/ TECHNICAL FLOORING

Vision Oxid

Pavimento tecnico con effetto pietra, cemento e graniglia, pensate per ambienti di grande modernità.

Technical flooring with stone, concrete, and speckled stone effects, designed for highly contemporary spaces.

Vision Oxid è la collezione progettata in formato tiles per interpretare al meglio le esigenze stilistiche di ambienti dal carattere contemporaneo e industriale. Una gamma che valorizza gli spazi con superfici materiche e un design moderno, capace di coniugare estetica e prestazioni di alto livello.

I suoi punti di forza sono la classe di resistenza all'abrasione AC6, che lo colloca tra i pavimenti tecnici più prestanti sul mercato, la protezione dall'acqua fino a 24 ore grazie alla tecnologia Hydro Plus e l'incastro TLS.PF, che consente una posa rapida e garantisce stabilità e precisione nel tempo.

Vision Oxid è inoltre certificato in classe Bfl-s1, caratteristica che lo rende adatto anche a spazi ad alto traffico come hotel, ristoranti e scuole, dove resistenza e sicurezza sono fondamentali.

Vision Oxid is the tile-format collection designed to best meet the stylistic needs of contemporary and industrial-inspired spaces.

A range that enhances interiors with textured surfaces and modern design, combining aesthetics with high-level performance.

Its strengths include an AC6 abrasion resistance rating, placing it among the most high-performing technical flooring on the market; water protection up to 24 hours thanks to Hydro Plus technology; and the TLS.PF locking system, which ensures quick installation as well as long-term stability and precision.

In addition, Vision Oxid is certified Bfl-s1, making it suitable even for high-traffic environments such as hotels, restaurants, and schools, where durability and safety are essential.



Product

Vision Oxid - Graniglia Bardiglio 1172

WARM GREY/ 1122

matt

1183x396x8 mm

CEMENTO SPATOLATO/ 1170

authentic

1184x601x8 mm

GRANIGLIA BARDIGLIO/ 1172

authentic

1184x601x8 mm

GRANIGLIA CARRARA/ 1173

authentic

1184x601x8 mm

GRANIGLIA MARQUINA/ 1174

authentic

1184x601x8 mm

GRANIGLIA BIANCO ROMANO/ 1176

authentic

1184x601x8 mm

CEMENTO GREZZO/ 3275

authentic

1184x601x8 mm



Dati tecnici Technical data

STRATIGRAFIA/ STRATIGRAPHY

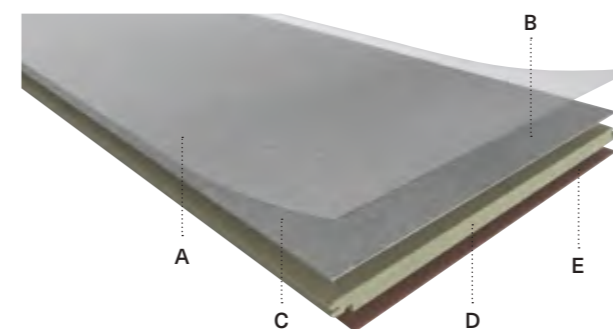

- A. Superficie High Wear**
High Wear surface
- B. Carta decorativa antistatica**
Antistatic decorative paper
- C. Strato intermedio HDF trattato**
Treated HDF intermediate layer
- D. Bordi trattati con Sigil joint**
Edges treated with Sigil joint
- E. Controilanciante**
Balancing layer

FORMATI/ FORMATS









Vision Oxid
1184×601×8 mm



Vision Oxid
1183×396×8 mm



CARATTERISTICHE TECNICHE/ TECHNICAL FEATURES

Incastro Joint		TLS.PF	Umidità/ resistenza all'acqua Moisture/ water resistant	
Bisello Bevel		Sincro bisello stampato sui 4 lati Syncro bevel printed on the 4 sides	Uso domestico Domestic use	 23 Alto Traffico High Traffic
Reazione al fuoco* Fire reaction*		Bfl-s1	Uso commerciale Commercial use	 33 Alto Traffico High Traffic
Riscaldamento a pavimento Radiant heating		T ≤ 27°C	Classe di abrasione Abrasion class	AC6
Antistatico Antistatic				

* Classificazione valida con l'utilizzo dei sottopavimenti e/o modalità indicate da Skema S.p.A. (per dettagli vedi scheda tecnica del prodotto e/o istruzioni per l'installazione).
* Classification valid with the use of underlayer and/or modality specified by Skema S.p.A. (please see product technical data sheet and/or installation instructions for details).

ACCESSORI/ ACCESSORIES

Sottopavimenti Underlayer	Superior RBR, DB, ST
Profilo Profile	Kit dislivello, kit dilatazione, kit terminale Splice kit, expansion kit, terminal kit
Battiscopa Skirting board	Time trendy, Look trendy

SPECIFICHE E CONFORMITÀ/ SPECIFICATIONS AND COMPLIANCE



CONFEZIONAMENTO/ PACKAGING

Rif. formato/ Size	Pezzi Cfz/ Pieces Box	m ² Cfz/ Box	Cfz Pallet/ Box Pallet	m ² Pallet
1183×396 mm	5	2,340	42	98,295
1184×601 mm	3	2,135	68	145,163

Vision Technic

**L'estetica di acciaio e pietra
ispira ambienti innovativi
e contemporanei.**

The aesthetics of steel and
stone inspire innovative,
contemporary spaces.

Vision Technic è la collezione di pavimenti tecnici in formato tiles (857x398x8 mm) progettata per il mondo allestitivo, contract e office, dove praticità e resistenza devono convivere con un'estetica tecnica e contemporanea. I decori, ispirati all'acciaio e alla pietra naturale, offrono superfici moderne e versatili, perfette per ambienti dinamici e professionali. I suoi punti di forza sono la rapidità e sicurezza di posa garantite dal sistema di incastro, la disponibilità della finitura anche per pavimenti sopraelevati, la resistenza all'abrasione e al calpestio e la certificazione di resistenza al fuoco. Caratteristiche che lo rendono una soluzione affidabile e funzionale, in grado di rispondere alle esigenze specifiche degli spazi pubblici e di lavoro.

Vision Technic is the technical flooring tile collection (857x398x8 mm) designed for the exhibition, contract, and office sectors, where practicality and durability must coexist with a technical and contemporary aesthetic. The décors, inspired by steel and natural stone, create modern and versatile surfaces, perfect for dynamic and professional environments. Its strengths include quick and secure installation ensured by the locking system, availability of the finish also for raised floors, high resistance to abrasion and foot traffic, and certified fire resistance. These features make it a reliable and functional solution, able to meet the specific demands of public and workspaces.



Product

Vision Technic - Pietra d'Istria 208

ACCIAIO BRUNITO/ 205

stone

857x398x8 mm

PIETRA PORTOGHESE/ 206

stone

857x398x8 mm

Dati tecnici Technical data

STRATIGRAFIA/ STRATIGRAPHY

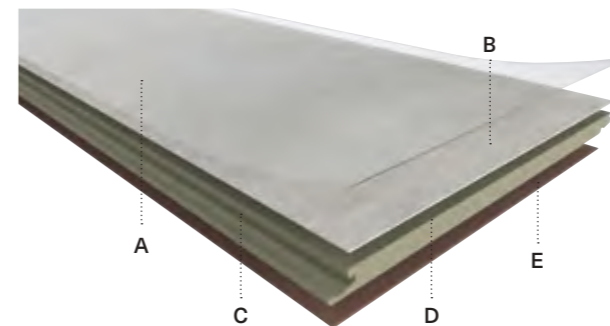

- A. Superficie High Wear**
High Wear surface
- B. Carta decorativa antistatica**
Antistatic decorative paper
- C. Strato intermedio HDF trattato**
Treated HDF intermediate layer
- D. Bordi trattati con Sigil joint**
Edges treated with Sigil joint
- E. Controilanciante**
Balancing layer

FORMATI/ FORMATS

Vision Technic
857×398×8 mm



CARATTERISTICHE TECNICHE/ TECHNICAL FEATURES

Incastro Joint		PLS	Umidità/ resistenza all'acqua Moisture/ water resistant	
Bisello Bevel		4V	Uso domestico Domestic use	 23 Alto Traffico High Traffic
Reazione al fuoco* Fire reaction*		Cfl-s1	Uso commerciale Commercial use	 32 Medio Traffico Medium Traffic
Riscaldamento a pavimento Radiant heating		T ≤ 27°C	Classe di abrasione Abrasion class	AC4
Antistatico Antistatic				

* Classificazione valida con l'utilizzo dei sottopavimenti e/o modalità indicate da Skema S.p.A. (per dettagli vedi scheda tecnica del prodotto e/o istruzioni per l'installazione).
* Classification valid with the use of underlayer and/or modality specified by Skema S.p.A. (please see product technical data sheet and/or installation instructions for details).

ACCESSORI/ ACCESSORIES

Sottopavimenti Underlayer	Superior RBR, DB, ST
Profilo Profile	Kit dislivello, kit dilatazione, kit terminale Splice kit, expansion kit, terminal kit
Battiscopa Skirting board	Time trendy, Look trendy

SPECIFICHE E CONFORMITÀ/ SPECIFICATIONS AND COMPLIANCE



CONFEZIONAMENTO/ PACKAGING

Rif. formato/ Size	Pezzi Cfz/ Pieces Box	m ² Cfz/ Box	Cfz Pallet/ Box Pallet	m ² Pallet
857×398 mm	7	2,387	30	71,610

PAVIMENTI IN SPC

SPC FLOORING

I pavimenti in SPC sono realizzati in materiale minerale riciclabile, polimeri e additivi che creano grande stabilità, resistenza all'acqua, ai graffi e alle variazioni termiche. Sono proposti con decori che riproducono il legno, il marmo, il metallo e la resina.

Per le loro caratteristiche fisiche, meccaniche ed estetiche, sono ideali per ambienti domestici, direzionali e commerciali.

In base alle esigenze di impiego possono essere provvisti di materassini fonoimpedenti, per un eccellente isolamento acustico.

SPC flooring is made from recyclable mineral materials, polymers, and additives that ensure excellent dimensional stability, resistance to water, scratches, and thermal variations. The collections feature décors inspired by wood, marble, metal, and resin.

Thanks to their physical, mechanical, and aesthetic properties, these floors are ideal for residential, office, and commercial spaces.

Depending on application requirements, they can be supplied with sound-absorbing underlays for excellent acoustic insulation.

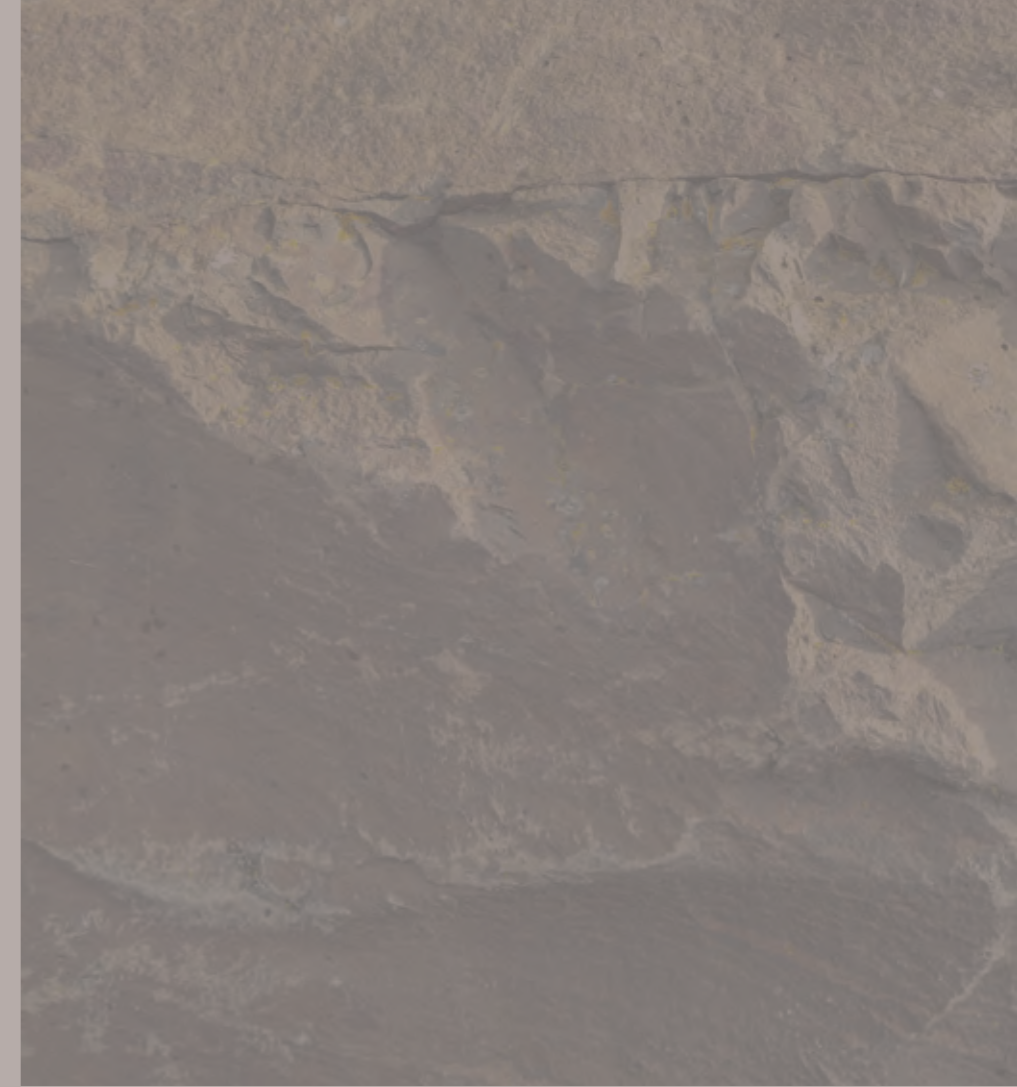

“Pavimenti evoluti che combinano prestazioni tecniche, estetica e facilità di posa.”

“Advanced flooring solutions that combine technical performance, refined aesthetics, and ease of installation.”

Star K

Estetica naturale ed elevate prestazioni in ogni ambiente.
Natural aesthetics and high performance in every environment.

Star K è il pavimento in SPC che integra perfettamente estetica, tecnica produttiva e prestazioni. Le grandi doghe con decoro legno garantiscono un effetto naturale adatto ad ogni ambientazione. La struttura multistrati semirigida (MMF), con anima in SPC, assicura un'eccellente stabilità dimensionale anche in presenza di sbalzi di temperatura. La resistenza all'abrasione, all'acqua, alle variazioni termiche e lo spessore ridotto rendono Star K il pavimento ideale per installazioni su pavimenti esistenti di qualsiasi tipo e anche in ambienti umidi. La superficie antiscivolo R10 ne garantisce l'applicabilità ad ambienti domestici, direzionali e commerciali. La dotazione del sottofondo preaccoppiato fonoimpedente rende Star K capace di garantire elevate prestazioni acustiche e quindi grande comfort ambientale.

Star K is an SPC flooring solution that perfectly combines aesthetics, manufacturing technology, and performance. The large wood-effect planks provide a natural look suitable for any interior design style. The semi-rigid multilayer (MMF) structure, with an SPC core, ensures excellent dimensional stability even under temperature fluctuations. Its resistance to abrasion, water, and thermal variations, together with its reduced thickness, makes Star K ideal for installation over existing floors of any type and even in humid environments. The R10 anti-slip surface ensures suitability for residential, office, and commercial applications. The integrated sound-absorbing underlay provides excellent acoustic performance and enhances overall environmental comfort.



Product
Star K - Barcellona 1205

TARRAGONA/ 1201
wood

1829x218x6 mm

ANVERSA/ 1202
real

1829x218x6 mm

* Stonalizzato
* Shade-varied

PAVIMENTI IN SPC/ SPC FLOORING

VALENCIA/ 1203

real

1829x218x6 mm

BARCELONA/ 1205

wood

1829x218x6 mm

MALTA/ 1210
wood

1829x218x6 mm

CORTINA/ 1212
wood

1829x218x6 mm

BILBAO/ 1213
natural

1829x218x6 mm

ROMA/ 1214
wood

1829x218x6 mm

* Stonalizzato
* Shade-varied

Dati tecnici Technical data

STRATIGRAFIA/ STRATIGRAPHY

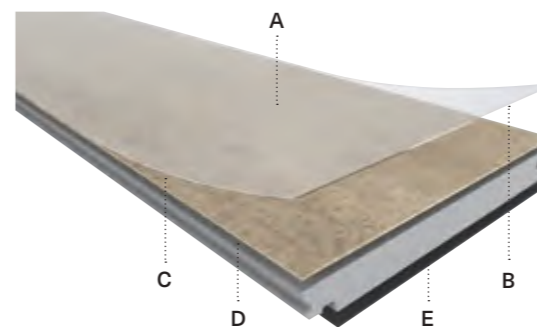

- A. Rivestimento anti-UV**
Anti-UV Coating
- B. Strato protettivo "Shell Star"**
Protective "Shell Star" layer
- C. Film vinilico decorativo**
Vinyl decorative film
- D. Cor.Star pannello in tecnologia SPC**
Cor.Star panel in SPC technology
- E. Sottopavimento acustico IXPE**
IXPE acoustic underlayer

FORMATI/ FORMATS

Star K
1829x218x6 mm



CARATTERISTICHE TECNICHE/ TECHNICAL FEATURES

Incastro Joint		5G™	Strato di usura Wear layer		0.55 mm
Bisello Bevel		Micro 4v	Uso domestico Domestic use		23 Alto Traffico High Traffic
Reazione al fuoco* Fire reaction*		Bfl-s1	Uso commerciale Commercial use		33 Alto Traffico High Traffic
Riscaldamento a pavimento Radiant heating		T ≤ 28°C	Scivolosità Slipperiness		DS

* Classificazione valida con l'utilizzo dei sottopavimenti e/o modalità indicate da Skema S.p.A. (per dettagli vedi scheda tecnica del prodotto e/o istruzioni per l'installazione).
* Classification valid with the use of underlayer and/or modality specified by Skema S.p.A. (please see product technical data sheet and/or installation instructions for details).

ACCESSORI/ ACCESSORIES

Sottopavimenti Underlayer	Integrato in IXPE** IXPE integrated**
Profilo Profile	Kit dislivello, kit dilatazione, kit terminale Splice kit, expansion kit, terminal kit
Battiscopa Skirting board	PVC Espanso Expanded PVC

** Skema indica di posare sempre la barriera vapore.
** Skema indicates to always lay the vapor barrier.

SPECIFICHE E CONFORMITÀ/ SPECIFICATIONS AND COMPLIANCE



CONFEZIONAMENTO/ PACKAGING

Rif. formato/ Size	Pezzi Cfz/ Pieces Box	m ² Cfz/ Box	Cfz Pallet/ Box Pallet	m ² Pallet
1829x218 mm***	4	1,594	68	108,452
1829x218 mm	6	2,392	48	114,819

*** Fino ad esaurimento scorte.
*** While supplies last.

Star KR

Decori effetto legno ultra realistici e prestazioni eccellenti.
Ultra-realistic wood-effect décors and excellent performance.

Star KR è la collezione SPC che abbina le caratteristiche tecniche dei pavimenti vinilici di ultima generazione alla tecnologia Sincroporo fino ad ottenere una superficie dall'effetto legno ultra realistico. Le finiture opache e l'effetto ultra matt esaltano i cromatismi naturali del legno e donano agli ambienti grande eleganza. La riproduzione dei decori risulta estremamente fedele sia alla vista che al tatto.

I suoi punti di forza sono lo spessore ridotto, che lo rende ideale per ristrutturazioni con posa diretta su pavimenti esistenti, la riproduzione del decoro a registro che sottolinea venature e lavorazioni superficiali con grande efficacia e la resistenza al fuoco, certificata in classe Bfl-s1, fondamentale per spazi pubblici e ad alta frequentazione come alberghi, ristoranti e scuole. Con Star KR il decoro naturale del legno raggiunge l'apice della qualità e unisce realismo estetico, prestazioni tecniche, funzionalità ed elevato livello estetico.

Star KR is the SPC collection that combines the technical features of next-generation vinyl flooring with embossed in registered pore technology, achieving an ultra-realistic wood-effect surface. The matte finishes and ultra-matt texture enhance the natural tones of wood, bringing a refined elegance to any space. The reproduction of the décors is remarkably true to life, both visually and to the touch. Its key strengths include a reduced thickness, ideal for renovations with direct installation over existing floors; registered embossing that highlights grain patterns and surface details with striking realism; and Bfl-s1 fire resistance certification, making it suitable for public and high-traffic areas such as hotels, restaurants, and schools.

With Star KR, the natural wood décor reaches its highest expression of quality, combining aesthetic realism, technical performance, functionality, and refined design.



Product
Star KR - Rovere Autentico 1216

ROVERE AUTENTICO/ 1216

emotion

1500x220x6 mm

ROVERE TERRANOVA/ 1233

emotion

1828x228x6 mm

QUERCIA FRANCESE/ 1234
emotion

1828x228x6 mm

FAGGIO CRUDO/ 1235
emotion

1828x228x6 mm

TEAK MEDIO/ 1236

emotion

1828x228x6 mm

ROVERE ALCALINO/ 1237

emotion

1828x228x6 mm

ROVERE OSSIDATO/ 1238

emotion

1828x228x6 mm



Dati tecnici Technical data

STRATIGRAFIA/ STRATIGRAPHY

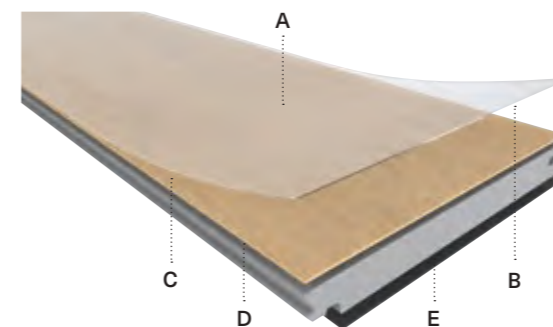









- A. Rivestimento anti-UV**
Anti-UV Coating
- B. Strato protettivo "Shell Star"**
Protective "Shell Star" layer
- C. Film vinilico decorativo a registro**
Registered decorative vinyl film
- D. Cor.Star pannello in tecnologia SPC**
Cor.Star panel in SPC technology
- E. Sottopavimento acustico IXPE**
IXPE acoustic underlayer

FORMATI/ FORMATS

Star KR
1500×220×6 mm

Star KR
1828×228×6 mm
1828×218×6 mm

CARATTERISTICHE TECNICHE/ TECHNICAL FEATURES

Incastro Joint		5G™	Strato di usura Wear layer		0.55 mm
Bisello Bevel		Micro 4v	Uso domestico Domestic use		23 Alto Traffico High Traffic
Sincroporo Synchropores		✓	Uso commerciale Commercial use		33 Alto Traffico High Traffic
Reazione al fuoco* Fire reaction*		Bfl-s1	Scivolosità Slipperiness		DS
Riscaldamento a pavimento Radiant heating		T ≤ 28°C			

* Classificazione valida con l'utilizzo dei sottopavimenti e/o modalità indicate da Skema S.p.A. (per dettagli vedi scheda tecnica del prodotto e/o istruzioni per l'installazione).
* Classification valid with the use of underlayer and/or modality specified by Skema S.p.A. (please see product technical data sheet and/or installation instructions for details).

ACCESSORI/ ACCESSORIES

Sottopavimenti Underlayer	Integrato in IXPE** IXPE integrated**
Profilo Profile	Kit dislivello, kit dilatazione, kit terminale Splice kit, expansion kit, terminal kit
Battiscopa Skirting board	PVC Espanso Expanded PVC

** Skema indica di posare sempre la barriera vapore.
** Skema indicates to always lay the vapor barrier.

SPECIFICHE E CONFORMITÀ/ SPECIFICATIONS AND COMPLIANCE



CONFEZIONAMENTO/ PACKAGING

Rif. formato/ Size	Pezzi Cfz/ Pieces Box	m² Cfz/ Box	Cfz Pallet/ Box Pallet	m² Pallet
1500×220 mm	6	1,980	56	110,880
1828×228 mm***	4	1,668	68	113,415
1828×218 mm	6	1,594	48	114,819

*** Fino ad esaurimento scorte.
*** While supplies last.

PAVIMENTI IN SPC/ SPC FLOORING

Star KC

SPC e sughero per un benessere acustico unico.
SPC and cork for exceptional acoustic comfort.

Star KC è il pavimento SPC integrato con sughero naturale, progettato per offrire comfort acustico superiore, elevata qualità estetica e ottima resistenza meccanica. Il suo spessore ridotto lo rende ideale per interventi di ristrutturazione con posa diretta su superfici esistenti, mentre le prestazioni acustiche e termiche lo distinguono come un prodotto unico nel suo genere. L'integrazione del sottopavimento in sughero migliora la percezione di calore al calpestio e il comfort ambientale complessivo. A queste caratteristiche si aggiungono le prestazioni tipiche degli SPC Skema, che ampliano le possibilità di applicazione in contesti residenziali, direzionali, ricettivi e commerciali. Star KC rappresenta l'espressione di una costante ricerca di qualità estetica e tecnica, pensata per soddisfare le esigenze di una clientela sempre più attenta e per garantire precisione, rapidità di posa e ottimale applicabilità in ogni intervento.

Star KC is an SPC flooring solution integrated with natural cork, designed to deliver superior acoustic comfort, refined aesthetics, and excellent mechanical strength. Its reduced thickness makes it ideal for renovation projects with direct installation over existing surfaces, while its acoustic and thermal performance set it apart as a truly unique product. The integration of the cork underlay enhances the perception of warmth underfoot and overall environmental comfort. These advantages are complemented by the typical performance features of Skema SPC floors, expanding its suitability for residential, office, hospitality, and commercial environments. Star KC represents the result of a continuous pursuit of aesthetic and technical excellence, created to meet the expectations of increasingly discerning clients while ensuring precision, installation speed, and optimal performance in every project.



Product
Star KC - Porto 1273

PAVIMENTI IN SPC/ SPC FLOORING

LEIRA/ 1270
wood

1500x228x6 mm

FARO/ 1271
wood

1500x228x6 mm

BRAGA/ 1272

wood

1500x228x6 mm

PORTO/ 1273

wood

1500x228x6 mm

COIMBRA/ 1274

wood

1500x228x6 mm



Dati tecnici Technical data

STRATIGRAFIA/ STRATIGRAPHY

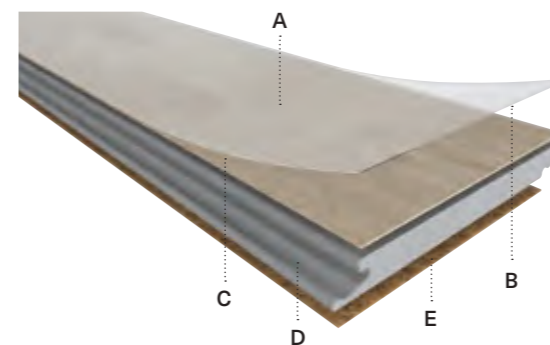

- A. Rivestimento anti-UV**
Anti-UV Coating
- B. Strato protettivo "Shell Star"**
Protective "Shell Star" layer
- C. Film vinilico decorativo**
Vinyl decorative film
- D. Cor.Star pannello in tecnologia SPC**
Cor.Star panel in SPC technology
- E. Sottopavimento acustico in sughero**
Cork acoustic underlayer

FORMATI/ FORMATS

Star KC
1500x228x6 mm



CARATTERISTICHE TECNICHE/ TECHNICAL FEATURES

Incastro Joint		PLS	Strato di usura Wear layer		0.55 mm
Bisello Bevel		Micro 4v	Uso domestico Domestic use		23 Alto Traffico High Traffic
Reazione al fuoco* Fire reaction*		Bfl-s1	Uso commerciale Commercial use		33 Alto Traffico High Traffic
Riscaldamento a pavimento Radiant heating		T ≤ 28°C	Scivolosità Slipperiness		DS

* Classificazione valida con l'utilizzo dei sottopavimenti e/o modalità indicate da Skema S.p.A. (per dettagli vedi scheda tecnica del prodotto e/o istruzioni per l'installazione).
* Classification valid with the use of underlayer and/or modality specified by Skema S.p.A. (please see product technical data sheet and/or installation instructions for details).

ACCESSORI/ ACCESSORIES

Sottopavimenti Underlayer	Integrato in sughero** Cork integrated**
Profilo Profile	Kit dislivello, kit dilatazione, kit terminale Splice kit, expansion kit, terminal kit
Battiscopa Skirting board	PVC Espanso Expanded PVC

** Skema indica di posare sempre la barriera vapore.
** Skema indicates to always lay the vapor barrier.

SPECIFICHE E CONFORMITÀ/ SPECIFICATIONS AND COMPLIANCE



CONFEZIONAMENTO/ PACKAGING

Rif. formato/ Size	Pezzi Cfz/ Pieces Box	m ² Cfz/ Box	Cfz Pallet/ Box Pallet	m ² Pallet
1500x228 mm	6	2,052	52	106,704

Star KS

L'eleganza della spina francese e le prestazioni dell'SPC.

The elegance of the French herringbone pattern and the performance of SPC.

Star KS unisce l'eleganza della posa a spina francese con le prestazioni avanzate di un pavimento SPC, creando un equilibrio perfetto tra tradizione e innovazione. Grazie alla tecnologia Endless, la superficie assicura un effetto continuo e uniforme, valorizzando il disegno senza interruzioni visive.

I suoi punti di forza sono lo spessore ridotto di soli 6 mm, che lo rende ideale anche per ristrutturazioni, il micro bisello sui quattro lati che definisce le geometrie con precisione e la superficie resistente all'acqua, caratteristica che permette di utilizzare il pattern a spina di pesce in contesti dove il parquet tradizionale non può essere impiegato.

Star KS rende possibile portare la bellezza della spina francese in ambienti pubblici e ad alto traffico, garantendo al tempo stesso praticità di posa, durabilità ed elevato livello estetico.

Star KS combines the elegance of the French herringbone installation with the advanced performance of SPC flooring, achieving a perfect balance between tradition and innovation. Thanks to Endless technology, the surface delivers a continuous and seamless visual effect, enhancing the pattern without interruptions.

Its key strengths include a reduced thickness of just 6 mm, ideal even for renovation projects; micro-beveling on all four sides, which precisely defines the geometry of each plank; and a water-resistant surface that allows the use of the herringbone pattern in spaces where traditional parquet would not be suitable.

Star KS brings the timeless beauty of the French herringbone design to public and high-traffic environments, while ensuring ease of installation, durability, and refined aesthetics.



Product
Star KS - Nantes 1227

PAVIMENTI IN SPC/ SPC FLOORING

NANTES/ 1227

emotion

1498x300x6 mm

MARSIGLIA/ 1228

emotion

1498x300x6 mm

Dati tecnici Technical data

STRATIGRAFIA/ STRATIGRAPHY

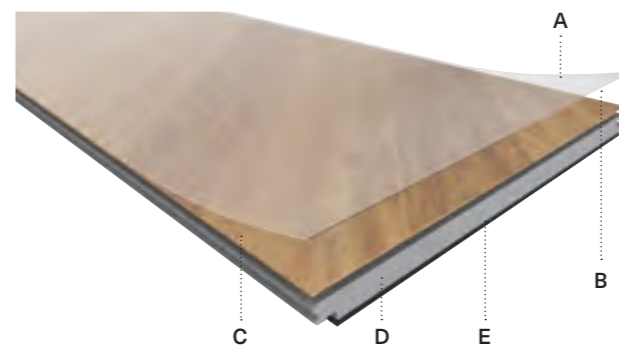

- A. Rivestimento anti-UV**
Anti-UV Coating
- B. Strato protettivo "Shell Star"**
Protective "Shell Star" layer
- C. Film vinilico decorativo**
Vinyl decorative film
- D. Cor.Star pannello in tecnologia SPC**
Cor.Star panel in SPC technology
- E. Sottopavimento acustico IXPE**
IXPE acoustic underlayer

FORMATI/ FORMATS

Star KS
1498x300x6 mm



CARATTERISTICHE TECNICHE/ TECHNICAL FEATURES

Incastro Joint		5G™	Strato di usura Wear layer		0.55 mm
Bisello Bevel		Micro 4v	Uso domestico Domestic use		23 Alto Traffico High Traffic
Sincroporo Synchropores		√ **	Uso commerciale Commercial use		33 Alto Traffico High Traffic
Reazione al fuoco* Fire reaction*		Bfl-s1	Scivolosità Slipperiness		DS
Riscaldamento a pavimento Radiant heating		T ≤ 28°C			

* Classificazione valida con l'utilizzo dei sottopavimenti e/o modalità indicate da Skema S.p.A. (per dettagli vedi scheda tecnica del prodotto e/o istruzioni per l'installazione).
* Classification valid with the use of underlayer and/or modality specified by Skema S.p.A. (please see product technical data sheet and/or installation instructions for details).

** Tecnologia Endless: il disallineamento dei biselli impressi non è da considerarsi un difetto ma un aspetto del prodotto.
** Endless Technology: misalignment of the imprinted bevels is not to be considered a defect but an aspect of the product.

ACCESSORI/ ACCESSORIES

Sottopavimenti Underlayer	Integrato in IXPE*** IXPE integrated***
Profilo Profile	Kit dislivello, kit dilatazione, kit terminale Splice kit, expansion kit, terminal kit
Battiscopa Skirting board	PVC Espanso Expanded PVC

*** Skema indica di posare sempre la barriera vapore.
*** Skema indicates to always lay the vapor barrier.

SPECIFICHE E CONFORMITÀ/ SPECIFICATIONS AND COMPLIANCE



CONFEZIONAMENTO/ PACKAGING

Rif. formato/ Size	Pezzi Cfz/ Pieces Box	m ² Cfz/ Box	Cfz Pallet/ Box Pallet	m ² Pallet
1498x300 mm	6	2,696	42	113,250

PAVIMENTI IN SPC/ SPC FLOORING

Star KD

Superfici materiche per spazi dal design innovativo.

Textured surfaces for spaces with innovative design.

Star KD è la collezione che reinterpreta in chiave contemporanea l'estetica di pietra, cemento e metallo, offrendo al tempo stesso le prestazioni tecniche avanzate di un pavimento in SPC. Proposto nel formato tile, definisce gli spazi con un linguaggio moderno e un carattere deciso.

I suoi punti di forza risiedono nella ricca varietà di decorativi materici, che spaziano tra tonalità e finiture capaci di soddisfare i gusti più attuali; nella superficie impermeabile, che assicura massima praticità e versatilità d'uso e nella piacevole sensazione di calore al calpestio, tipica dei pavimenti SPC. Con Star KD, l'effetto materico incontra comfort e funzionalità, dando vita a una soluzione ideale per ambienti contemporanei che ricercano alte performance tecniche senza rinunciare al benessere abitativo.

Star KD is the collection that reinterprets the aesthetics of stone, concrete, and metal in a contemporary way, while offering the advanced technical performance of SPC flooring. Presented in a tile format, it defines spaces with a modern and distinctive character. Its key strengths include a wide range of textured décors, featuring tones and finishes designed to meet the most current design trends; a waterproof surface that ensures maximum practicality and versatility of use; and the pleasant sense of warmth underfoot typical of SPC floors.

With Star KD, the material effect merges with comfort and functionality, creating the ideal solution for contemporary interiors that seek high technical performance without compromising on living comfort and style.



Product
Star KD - Cardiff 1209

PAVIMENTI IN SPC/ SPC FLOORING

BRUGES/ 1208

stone

914x457x6 mm

CARDIFF/ 1209

stone

914x457x6 mm

RESINA/ 1221

stone

914x457x6 mm

BARRY/ 1223

stone

914x457x6 mm

NEWPORT/ 1224
stone

914x457x6 mm

CORTEN/ 1225
stone

914x457x6 mm

Dati tecnici Technical data

STRATIGRAFIA/ STRATIGRAPHY

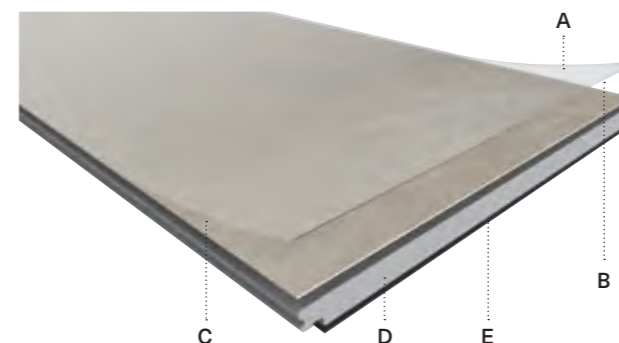

- A. Rivestimento anti-UV**
Anti-UV Coating
- B. Strato protettivo "Shell Star"**
Protective "Shell Star" layer
- C. Film vinilico decorativo**
Vinyl decorative film
- D. Cor.Star pannello in tecnologia SPC**
Cor.Star panel in SPC technology
- E. Sottopavimento acustico IXPE**
IXPE acoustic underlayer

FORMATI/ FORMATS

Star KD
914x457x6 mm



CARATTERISTICHE TECNICHE/ TECHNICAL FEATURES

Incastro Joint		5G™	Strato di usura Wear layer		0.55 mm
Bisello Bevel		Micro 4v	Uso domestico Domestic use		23 Alto Traffico High Traffic
Reazione al fuoco* Fire reaction*		Bfl-s1	Uso commerciale Commercial use		33 Alto Traffico High Traffic
Riscaldamento a pavimento Radiant heating		T ≤ 28°C	Scivolosità Slipperiness		DS

* Classificazione valida con l'utilizzo dei sottopavimenti e/o modalità indicate da Skema S.p.A. (per dettagli vedi scheda tecnica del prodotto e/o istruzioni per l'installazione).
* Classification valid with the use of underlayer and/or modality specified by Skema S.p.A. (please see product technical data sheet and/or installation instructions for details).

ACCESSORI/ ACCESSORIES

Sottopavimenti Underlayer	Integrato in IXPE** IXPE integrated**
Profilo Profile	Kit dislivello, kit dilatazione, kit terminale Splice kit, expansion kit, terminal kit
Battiscopa Skirting board	PVC Espanso Expanded PVC

** Skema indica di posare sempre la barriera vapore.
** Skema indicates to always lay the vapor barrier.

SPECIFICHE E CONFORMITÀ/ SPECIFICATIONS AND COMPLIANCE



CONFEZIONAMENTO/ PACKAGING

Rif. formato/ Size	Pezzi Cfz/ Pieces Box	m² Cfz/ Box	Cfz Pallet/ Box Pallet	m² Pallet
914x457 mm	6	2,506	40	100,335

Connex

Robustezza, basso spessore e prestazioni acustiche.

Strength, low thickness and acoustic performance.

Connex è il pavimento SPC che si distingue per un profilo tecnico unico all'interno della gamma Skema. Resistente e sottile, è progettato per offrire prestazioni elevate in ambienti ad alto traffico, grazie a una struttura innovativa che combina robustezza, comfort acustico e praticità d'uso. I suoi punti di forza sono lo spessore ridotto di soli 4,5 mm, più 1 mm di sottopavimento preaccoppiato che ne agevola la posa e ne amplia la versatilità, la classe di resistenza 33, ideale per aree ad alto traffico e l'incastro 5Gi che garantisce stabilità e rapidità d'installazione. Il materassino in IXPE integrato attenua il rumore da calpestio e migliora il comfort ambientale, mentre lo strato protettivo da 0,55 mm, rinforzato con poliuretano, assicura durabilità, resistenza chimica e facilità di manutenzione. Connex è l'SPC ultrasottile dalle ottime prestazioni, la scelta ideale per spazi commerciali che richiedono affidabilità, comfort e design contemporaneo.

Connex is the SPC flooring that stands out for its unique technical profile within the Skema range. Strong yet thin, it is designed to deliver high performance in commercial environments, thanks to an innovative structure that combines durability, acoustic comfort, and practicality. Its key features include a reduced thickness of just 4.5 mm (plus 1 mm of pre-attached underlay), which enhances flexibility and ease of installation; use class 33, suitable for high-traffic areas; and the 5Gi locking system, ensuring stability and installation speed. The built-in IXPE underlayment reduces footstep and ambient noise, while the 0.55 mm protective wear layer, reinforced with PU coating, provides durability, chemical resistance, and easy maintenance. Connex is the ultra-thin SPC with enhanced performance—the ideal choice for commercial spaces that demand reliability, comfort, and contemporary design.

Product
Connex - Rovere Crudo 1100

PAVIMENTI IN SPC/ SPC FLOORING

ROVERE CRUDO/ 1100
wood

1500x180x5,5 mm

ROVERE CANADESE/ 1104
wood

1500x180x5,5 mm

BALTIC OAK/ 1115

wood

1500x180x5,5 mm

ROVERE CONGO/ 1137

wood

1500x180x5,5 mm

ROVERE BRITANNICO/ 1138

wood

1500x180x5,5 mm

ROVERE NORDICO/ 1139

wood

1500x180x5,5 mm

Dati tecnici Technical data

STRATIGRAFIA/ STRATIGRAPHY

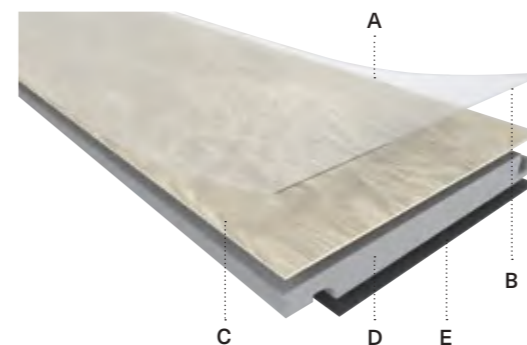

- A. Rivestimento anti-UV**
Anti-UV Coating
- B. Strato protettivo "Shell Star"**
Protective "Shell Star" layer
- C. Film vinilico decorativo**
Vinyl decorative film
- D. Cor.Star pannello in tecnologia SPC**
Cor.Star panel in SPC technology
- E. Sottopavimento acustico IXPE**
IXPE acoustic underlayer

FORMATI/ FORMATS

Connex
1500x180x5,5 mm



CARATTERISTICHE TECNICHE/ TECHNICAL FEATURES

Incastro Joint		5Gi™	Strato di usura Wear layer		0.55 mm
Bisello Bevel		Micro 4v	Uso domestico Domestic use		23 Alto Traffico High Traffic
Reazione al fuoco* Fire reaction*		Bfl-s1	Uso commerciale Commercial use		33 Alto Traffico High Traffic
Riscaldamento a pavimento Radiant heating		T ≤ 28°C	Scivolosità Slipperiness		DS

* Classificazione valida con l'utilizzo dei sottopavimenti e/o modalità indicate da Skema S.p.A. (per dettagli vedi scheda tecnica del prodotto e/o istruzioni per l'installazione).
* Classification valid with the use of underlayer and/or modality specified by Skema S.p.A. (please see product technical data sheet and/or installation instructions for details).

ACCESSORI/ ACCESSORIES

Sottopavimenti Underlayer	Integrato in IXPE** IXPE integrated**
Profilo Profile	Kit dislivello, kit dilatazione, kit terminale Splice kit, expansion kit, terminal kit
Battiscopa Skirting board	PVC Espanso Expanded PVC

** Skema indica di posare sempre la barriera vapore.
** Skema indicates to always lay the vapor barrier.

SPECIFICHE E CONFORMITÀ/ SPECIFICATIONS AND COMPLIANCE



CONFEZIONAMENTO/ PACKAGING

Rif. formato/ Size	Pezzi Cfz/ Pieces Box	m ² Cfz/ Box	Cfz Pallet/ Box Pallet	m ² Pallet
1500x180 mm	8	2,16	50	108

Star Wood

Una combinazione vincente di vero legno ed SPC.

A winning combination of real wood and SPC.

Star Wood è una superficie che ridefinisce il concetto di pavimento tecnologico, combinando l'autenticità del vero legno di rovere con la tecnologia evoluta dell'SPC e il sottopavimento in sughero naturale. Con uno spessore totale di soli 7 mm, rappresenta una soluzione sottile e funzionale, ideale sia per nuove realizzazioni che per interventi di ristrutturazione, senza rinunciare al pregio dei materiali naturali.

I suoi punti di forza includono il rivestimento in tranciato di legno nobile da 1 mm, che valorizza le venature e la matericità del rovere; il nucleo in SPC, che garantisce stabilità dimensionale e resistenza all'acqua; e il materassino in sughero preaccoppiato, che offre ottimo isolamento acustico e termico. Certificato in classe di reazione al fuoco Bfl-s1, Star Wood è adatto a contesti residenziali e professionali. Disponibile con finiture naturali o rustiche, esprime al meglio l'incontro tra design e sostenibilità, riducendo l'uso di materia prima e contribuendo alla tutela delle foreste.

È una superficie innovativa, resistente e silenziosa, che unisce la bellezza del legno autentico alle prestazioni avanzate della tecnologia SPC.

La gamma si completa con Star Wood Spina, proposta nel formato spina italiana 100x600 mm con elementi destri e sinistri, ideale non solo per ambienti residenziali, ma anche per spazi direzionali e Ho.Re.Ca.

Star Wood is a surface that redefines the concept of technological flooring, combining the authenticity of real oak wood with advanced SPC technology and a natural cork underlay. With a total thickness of only 7 mm, it offers a thin yet functional solution, ideal for both new constructions and renovation projects, without compromising on the quality of natural materials.

Its key features include a 1 mm veneer of genuine noble oak, enhancing the grain and texture of the wood; an SPC core that ensures dimensional stability and water resistance; and a pre-attached cork underlay that provides excellent acoustic and thermal insulation. Certified in fire reaction class Bfl-s1, Star Wood is suitable for both residential and professional environments.

Available in natural and rustic finishes, it perfectly expresses the balance between design and sustainability, reducing the use of raw materials and contributing to forest preservation.

This innovative, durable, and quiet surface combines the beauty of authentic wood with the high performance of SPC technology.

The range is completed by Star Wood Spina, available in the Italian herringbone format 100x600 mm, with right and left elements, ideal not only for residential interiors but also for office, hospitality, and contract spaces.



Product

Star Wood - Rovere Champagne Spina 1621

ROVERE PINOT/ 1600

rustico

1900x190x7 mm

ROVERE WHISKY/ 1601

nature

1900x190x7 mm

ROVERE ARABICA/ 1602

rustico

1900x190x7 mm

ROVERE COGNAC/ 1603-1606

rustico

1218x165x7 mm

1900x190x7 mm

ROVERE CHAMPAGNE/ 1604-1607

nature

1218x165x7 mm

1900x190x7 mm

NOCE BRANDY/ 1605

nature

1218x165x7 mm

ROVERE WHISKY SPINA/ 1620

nature

600x100x7 mm

ROVERE CHAMPAGNE SPINA/ 1621

nature

600x100x7 mm

Dati tecnici Technical data

STRATIGRAFIA/ STRATIGRAPHY

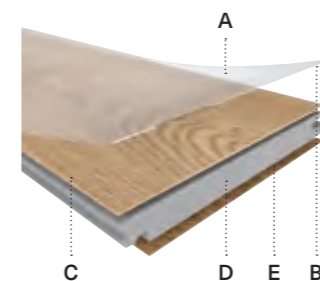

Star Wood

- A. Rivestimento anti-UV**
Anti-UV Coating
- B. Strato protettivo "Shell Star"**
Protective "Shell Star" Layer
- C. Strato di vero legno**
Layer of real wood
- D. Cor.Star pannello in tecnologia SPC**
Cor.Star panel in SPC technology
- E. Sottopavimento acustico in sughero**
Cork acoustic underlayer

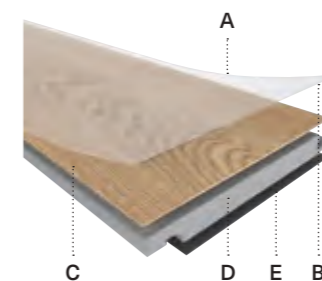

Star Wood Spina

- A. Rivestimento anti-UV**
Anti-UV Coating
- B. Strato protettivo "Shell Star"**
Protective "Shell Star" Layer
- C. Strato di vero legno**
Layer of real wood
- D. Cor.Star pannello in tecnologia SPC**
Cor.Star panel in SPC technology
- E. Sottopavimento acustico IXPE**
IXPE acoustic underlayer

FORMATI/ FORMATS

Star Wood

1218x165x7 mm



Star Wood

1900x190x7 mm



Star Wood Spina

600x100x7 mm



CARATTERISTICHE TECNICHE/ TECHNICAL FEATURES

Incastro
Joint



5G™
(Star Wood)

Bisello
Bevel



Micro 4v



Unidrop
(Star Wood Spina)

Riscaldamento a pavimento
Radiant heating



T ≤ 28°C

Reazione al fuoco*
Fire reaction*



Bfl-s1
(Star Wood)

Formaldeide
Formaldehyde



E1



Cfl-s1
(Star Wood Spina)

* Classificazione valida con l'utilizzo dei sottopavimenti e/o modalità indicate da Skema S.p.A. (per dettagli vedi scheda tecnica del prodotto e/o istruzioni per l'installazione).
* Classification valid with the use of underlayer and/or modality specified by Skema S.p.A. (please see product technical data sheet and/or installation instructions for details).

ACCESSORI/ ACCESSORIES

Sottopavimenti
Underlayer

Per dogia - integrato in sughero**
For slat - Integrated cork**

Per spina - integrato in IXPE**
For chevron - Integrated in IXPE**

Profilo
Profile

Kit dislivello, kit dilatazione, kit terminale
Splice kit, expansion kit, terminal kit

Battiscopa
Skirting board

PVC Espanso
Expanded PVC

** Skema indica di posare sempre la barriera vapore.
** Skema indicates to always lay the vapor barrier.

SPECIFICHE E CONFORMITÀ/ SPECIFICATIONS AND COMPLIANCE



CONFEZIONAMENTO/ PACKAGING

Rif. formato/ Size	Pezzi Cfz/ Pieces Box	m² Cfz/ Box	Cfz Pallet/ Box Pallet	m² Pallet
1218x165 mm	8	1,607	72	125,405
1900x190 mm	6	2,166	55	119,13
600x100 mm	14	0,84	144	120,96

PAVIMENTI IN SPC/ SPC FLOORING

Top Level Lumbertech

Il legno tecnico integra estetica e prestazioni, aumentando il valore intrinseco e quello percepito.

Technical wood blends beauty and performance, elevating both its essence and the way it is experienced.

La rivoluzione del pavimento in legno si esprime anche nella versione sopraelevata: Lumbertech è una superficie innovativa, certificata e sostenibile, proposta in un'ampia gamma di decori per rispondere alle più diverse esigenze progettuali. I pannelli, applicabili alla struttura regolabile, possono essere realizzati in truciolare o in solfato di calcio, permettendo di scegliere la soluzione più adatta in base ai requisiti di resistenza, stabilità e prestazioni acustiche richieste dal cliente. Lumbertech, nei pavimenti sopraelevati, rappresenta la sintesi tra innovazione, sostenibilità e design, offrendo al progettista la possibilità di introdurre il legno e il suo valore estetico in ambienti in cui usualmente si prediligono le superfici fredde, garantendo naturalità, funzionalità e prestazioni elevate.

The revolution in wood flooring also extends to raised access applications: Lumbertech is an innovative, certified, and sustainable surface, offered in a wide range of decors to meet diverse design requirements. The panels, applied onto the adjustable structure, can be manufactured in chipboard or calcium sulphate, allowing the most suitable solution to be chosen according to specific demands for strength, stability, and acoustic performance. In raised access floors, Lumbertech represents the perfect synthesis of innovation, sustainability, and design, giving designers the opportunity to introduce wood and its aesthetic value into environments traditionally dominated by colder surfaces, while ensuring natural appeal, functionality, and outstanding performance.



Product

Top Level Lumbertech - Rovere Brenta

PAVIMENTI SOPRAELEVATI/ RAISED FLOORING

ROVERE ARCHES/ 1438-1453

600x600x39 mm
600x600x41 mm

ROVERE ONTARIO/ 1440-1452

600x600x39 mm
600x600x41 mm

ROVERE BRENTA/ 1451-1455

600x600x39 mm

600x600x41 mm



Dati tecnici

Technical data

STRATIGRAFIA/ STRATIGRAPHY

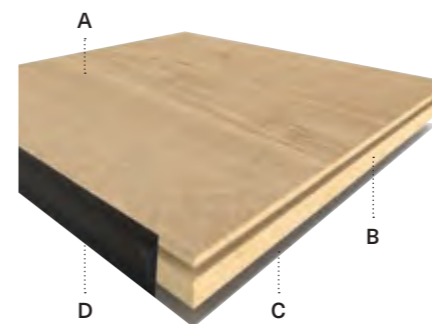



- A. Rivestimento con pavimento Lumbertech**
Lumbertech flooring covering
- B. Pannello di truciolare o solfato di calcio**
Particleboard or calcium sulphate panel
- C. Foglio di alluminio**
Aluminum foil
- D. Bordo in ABS nero**
Black ABS edge

FORMATI/ FORMATS

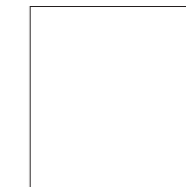
Top Level Lumbertech
600×600×39/41 mm



CARATTERISTICHE TECNICHE/ TECHNICAL FEATURES

Reazione al fuoco Fire reaction		Bfl-s1	Resistenza all'urto di corpi duri e morbidi Impact resistance of hard and soft bodies	Test superato Test passed
Formaldeide Formaldehyde		E1	Deformazione permanente dopo il carico Permanent deformation after loading EN 12825	< 0,5 mm
Pannello Panel	Truciolare o solfato di calcio Particleboard or calcium sulphate		Carico massimo di rottura Maximum breaking load	Vedi scheda tecnica See data sheet
			Classe dell'elemento Element class EN 12825	

CONFEZIONAMENTO/ PACKAGING

Rif. formato/ Size	Pezzi Cfz/ Pieces Box	m ² Cfz/ Box	Cfz Pallet/ Box Pallet	m ² Pallet
600×600 mm	1	0,36	48/ 56	VAR

Top Level Prestige L

L'evoluzione estetica del pavimento tecnico effetto legno esalta il valore del sopraelevato.

The aesthetic evolution of wood-effect technical flooring enhances the value of the raised floor.

Prestige L è il pavimento tecnico effetto legno pensato per offrire un rivestimento resistente e dalle caratteristiche tecniche evolute, ideale per rispondere alle esigenze degli spazi collettivi e professionali. È la scelta perfetta per chi desidera la praticità di un pavimento tecnico senza rinunciare all'estetica naturale del legno.

I suoi punti di forza sono la possibilità di scegliere tra pannelli in truciolare o in solfato di calcio, in base ai requisiti di resistenza, stabilità e prestazioni acustiche, e l'integrazione con la gamma sopraelevata Skema, che consente di abbinare superfici differenti mantenendo coerenza estetica e funzionale.

Prestige L is a wood-effect technical flooring designed to provide a durable surface with advanced technical features, making it ideal for the demands of collective and professional spaces. It is the perfect choice for those who want the practicality of technical flooring without compromising on the natural aesthetics of wood.

Its key strengths include the option of panels in chipboard or calcium sulphate - depending on the required levels of resistance, stability, and acoustic performance - and its integration with Skema's raised access floor systems, which allows for the combination of different surfaces while maintaining both aesthetic and functional consistency.



Product

Top Level Prestige L - Rovere Senese

GREY OAK/ 168
natural

600x600x36 mm
600x600x38 mm

ROVERE SENESE/ 250
natural

600x600x36 mm
600x600x38 mm

NOCE AUTENTICO/ 178
modern

600x600x36 mm
600x600x38 mm

PEPPER OAK/ 372
emotion

600x600x36 mm
600x600x38 mm

Dati tecnici

Technical data

STRATIGRAFIA/ STRATIGRAPHY

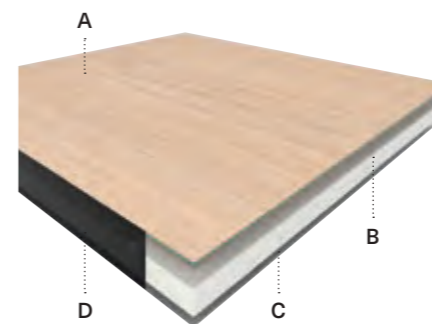



- A. Rivestimento con pavimento Prestige L**
Prestige L flooring covering
- B. Pannello di solfato di calcio o truciolare**
Particleboard or calcium sulphate panel
- C. Foglio di alluminio**
Aluminum foil
- D. Bordo in ABS nero**
Black ABS edge

FORMATI/ FORMATS

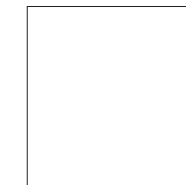
Top Level Prestige L
600×600×36/38 mm



CARATTERISTICHE TECNICHE/ TECHNICAL FEATURES

Reazione al fuoco Fire reaction		Bfl-s1	Resistenza all'urto di corpi duri e morbidi Impact resistance of hard and soft bodies	Test superato Test passed
Formaldeide Formaldehyde		E1	Deformazione permanente dopo il carico Permanent deformation after loading EN 12825	< 0,5 mm
Classe di abrasione Abrasion class			Carico massimo di rottura Maximum breaking load	Vedi scheda tecnica See data sheet
Pannello Panel		Truciolare o solfato di calcio Particleboard or calcium sulphate	Classe dell'elemento Element class EN 12825	

CONFEZIONAMENTO/ PACKAGING

Rif. formato / Size	Pezzi Cfz/ Pieces Box	m ² Cfz/ Box	Cfz Pallet/ Box Pallet	m ² Pallet
600×600 mm	1	0,36	48/ 56	VAR

Top Level Vision Technic

Design tecnico e decori materici esaltano la funzionalità del pavimento sopraelevato.
Technical design and material-inspired decors enhance the functionality of raised access flooring.

Vision Technic è la collezione di pavimenti tecnici che interpreta in chiave contemporanea l'estetica dell'acciaio e della pietra, con superfici dall'impatto tecnico e moderno. Unisce le performance del pavimento tecnico alla forza espressiva dei decori materici, offrendo soluzioni ideali per ambienti ad uso pubblico ad alto traffico.

Al progettista e al cliente viene offerta una doppia possibilità di scelta: il materiale più adatto, solfato di calcio o truciolare, per soddisfare i requisiti acustici e di resistenza meccanica necessari, in base alle specifiche applicazioni; i due decori ad effetto pietra e metallo per creare l'effetto estetico voluto.

Vision Technic is the collection of technical flooring that reinterprets the aesthetics of steel and stone in a contemporary key, with surfaces that convey a distinctly technical and modern impact. It combines the performance of technical flooring with the expressive strength of material inspired decors, offering ideal solutions for high-traffic public spaces. Both designers and clients are offered a dual choice: the most suitable core material - calcium sulphate or chipboard - to meet specific acoustic and mechanical resistance requirements, depending on the application; and two stone and metal effect decors to achieve the desired aesthetic result.



Product
Top Level Vision Technic - Pietra Carnica

PAVIMENTI SOPRAELEVATI/ RAISED FLOORING

PIETRA PORTOGHESE/ 206

600x600x36 mm
600x600x38 mm

PIETRA CARNICA/ 207

600x600x36 mm
600x600x38 mm

Dati tecnici

Technical data

STRATIGRAFIA/ STRATIGRAPHY

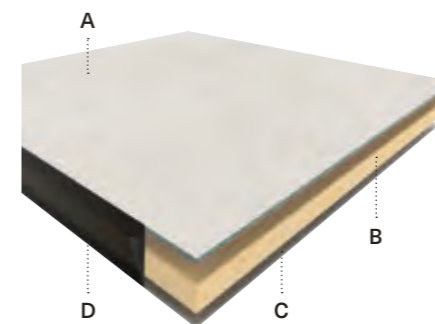



- A. Rivestimento con pavimento Vision Technic**
Vision Technic flooring covering
- B. Pannello di truciolare o solfato di calcio**
Chipboard panel or calcium sulfate
- C. Foglio di alluminio**
Aluminum foil
- D. Bordo in ABS nero**
Black ABS edge

FORMATI/ FORMATS

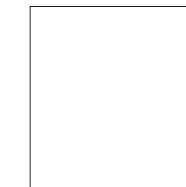
Top Level Vision Technic
600×600×36/38 mm



CARATTERISTICHE TECNICHE/ TECHNICAL FEATURES

Reazione al fuoco Fire reaction		Bfl-s1	Resistenza all'urto di corpi duri e morbidi Impact resistance of hard and soft bodies	Test superato Test passed
Formaldeide Formaldehyde		E1	Deformazione permanente dopo il carico Permanent deformation after loading EN 12825	< 0,5 mm
Classe di abrasione Abrasion class			Carico massimo di rottura Maximum breaking load	Vedi scheda tecnica See data sheet
Pannello Panel		Truciolare o solfato di calcio Particleboard or calcium sulphate	Classe dell'elemento Element class EN 12825	

CONFEZIONAMENTO/ PACKAGING

Rif. formato/ Size	Pezzi Cfz/ Pieces Box	m ² Cfz/ Box	Cfz Pallet/ Box Pallet	m ² Pallet
600×600 mm	1	0,36	48 / 56	VAR

Tech Wall

**Un rivestimento continuo
che dona tridimensionalità
alle superfici.**

A continuous cladding
that gives surfaces
a three-dimensional effect.

Tech Wall è il sistema di rivestimento per pareti e soffitti che unisce grande impatto visivo e semplicità di installazione. Un concept a doghe disponibile in tre varianti estetiche, capace di coniugare design, funzionalità e sicurezza. Realizzato in MDF, si distingue per la lunghezza delle doghe, l'ampia scelta di decori a catalogo, la versione grezza tinteggiabile in opera, le basse emissioni di formaldeide e la certificazione di reazione al fuoco che ne consente l'utilizzo anche in ambienti pubblici.

Tre le versioni disponibili: TW1 con dogha liscia, TW2 con dogha 3D rigata a elementi rettangolari, TW3 con dogha 3D rigata a elementi semicilindrici.

Grazie alle connessioni maschio/femmina a scomparsa, Tech Wall assicura rivestimenti continui, senza interruzioni visive, che esaltano l'uniformità e l'eleganza delle superfici. Le prestazioni tecniche e la versatilità applicativa rendono Tech Wall la soluzione ideale per residenze private, uffici, spazi commerciali e per il mondo HO.RE.CA.

Tech Wall is the wall and ceiling cladding system that combines strong visual impact with ease of installation.

A slatted concept available in three aesthetic variants, it merges design, functionality, and safety.

Made of MDF, it stands out for the length of its slats, the wide range of decors available in the catalogue, the raw version that can be painted on-site, its low formaldehyde emissions, and the fire reaction classification that makes it suitable for use in public spaces.

Three versions are available: TW1 with smooth slat, TW2 with 3D grooved slat featuring rectangular elements, TW3 with 3D grooved slat featuring semicylindrical elements. Thanks to concealed tongue-and-groove connections, Tech Wall guarantees continuous surfaces without visible joints, ensuring uniformity and a refined aesthetic. Its technical characteristics and versatile performance make Tech Wall the ideal solution for private residences, offices, retail environments, and the HO.RE.CA. sector.

Product

Tech Wall - Timber TW2

RAW OAK/ 1681
TW1

3040x166x12 mm

TIMBER/ 1682
TW1

3040x166x12 mm

NUX/ 1683
TW1

3040x166x12 mm

PAINT/ 1685
TW1

3040x166x12 mm

MONOCHROME
TW1

3040x166x12 mm

* Ordine minimo 500mq
* Minimum order 500 sqm

** Colore a campione
** Sample color

RAW OAK/ 1681
TW2

3040x166x12 mm

TIMBER/ 1682
TW2

3040x166x12 mm

NUX/ 1683
TW2

3040x166x12 mm

PAINT/ 1685
TW2

3040x166x12 mm

MONOCHROME
TW2

3040x166x12 mm

* **Ordine minimo 500mq**
* **Minimum order 500 sqm**

** **Colore a campione**
** **Sample color**

RAW OAK/ 1681
TW3

3040x166x12 mm

TIMBER/ 1682
TW3

3040x166x12 mm

NUX/ 1683
TW3

3040x166x12 mm

PAINT/ 1685
TW3

3040x166x12 mm

MONOCHROME
TW3

3040x166x12 mm

* Ordine minimo 500mq
* Minimum order 500 sqm

** Colore a campione
** Sample color

PATTERN/ 1684
TW2

3040x166x12 mm

Dati tecnici
Technical data

STRATIGRAFIA/ STRATIGRAPHY



Tech Wall

- A. Pannello in MDF
MDF panel
- B. Carta decorativa
Decorative paper

Tech Wall Paint

- A. Pannello in MDF
MDF panel

FORMATI/ FORMATS

Tech Wall
3040x166x12 mm



PATTERN

TW1



TW2



TW3



CARATTERISTICHE TECNICHE/ TECHNICAL FEATURES

Reazione al fuoco a parete*
Wall fire reaction*



B-s2, d0
escluso Tech Wall
Paint excluding
Tech Wall Paint

Formaldeide
Formaldehyde



E1

* Classificazione valida con modalità indicate da Skema S.p.A. (per dettagli vedi scheda tecnica del prodotto e/o istruzioni per l'installazione).
* Classification valid with the modality specified by Skema S.p.A. (please see product technical data sheet and/or installation instructions for details).

SPECIFICHE E CONFORMITÀ/ SPECIFICATIONS AND COMPLIANCE



** Escluso Tech Wall Paint
** Excluding Tech Wall Paint

CONFEZIONAMENTO/ PACKAGING

Rif. formato/ Size	Pezzi Cfz/ Pieces Box	m ² Cfz/ Box	Cfz Pallet/ Box Pallet	m ² Pallet
3040x166 mm	5	2,523	44	111,012

RIVESTIMENTI A PARETE E SOFFITTO/ WALL AND CEILING COVERINGS

Star KW

Superfici composite che uniscono innovazione, design e praticità.

Composite surfaces that combine innovation, design, and practicality.

Star KW è il rivestimento a parete in SPC (Stone Polymer Composite) a basso spessore che reinterpreta con stile contemporaneo l'estetica di pietra e cemento. I decori sono perfettamente coordinati con quelli del pavimento Star KD e permettono un abbinamento armonico tra superfici verticali e orizzontali.

Il ridotto spessore consente un'installazione rapida anche su rivestimenti esistenti, mentre la resistenza all'acqua e l'assenza di fughe lo rendono ideale per ambienti umidi come bagni e cucine. La posa è estremamente pratica grazie all'incastro evoluto e alle grandi dimensioni delle quadrotte.

Con Star KW il rivestimento diventa funzionale e scenografico allo stesso tempo: una soluzione moderna, resistente e versatile per rinnovare spazi residenziali e pubblici con coerenza estetica e massima praticità.

Star KW is a low-thickness SPC (Stone Polymer Composite) wall covering that reinterprets the aesthetics of stone and concrete with a contemporary style. The decors are perfectly coordinated with those of Star KD flooring, creating a harmonious match between vertical and horizontal surfaces.

Its reduced thickness allows for quick installation even over existing coverings, while its water resistance and seamless finish make it ideal for humid environments such as bathrooms and kitchens. Installation is made extremely easy thanks to the advanced click system and the large format of the tiles.

With Star KW, wall cladding becomes both functional and scenographic: a modern, durable, and versatile solution for renovating residential and public spaces with aesthetic consistency and maximum practicality.



Product

Star KW - Cardiff 1209

CARDIFF/ 1209

stone

1210x457x4 mm

LIEGI/ 1220

stone

1210x457x4 mm

BARRY/ 1223

stone

1210x457x4 mm

NEWPORT/ 1224

stone

1210x457x4 mm

Dati tecnici Technical data

STRATIGRAFIA/ STRATIGRAPHY



- A. Rivestimento anti-UV**
Anti-UV Coating
- B. Strato protettivo "Shell Star"**
Protective "Shell Star" layer
- C. Film vinilico decorativo**
Vinyl decorative film
- D. Cor.Star pannello in tecnologia SPC**
Cor.Star panel in SPC technology

FORMATI/ FORMATS

Star KW
1210x457x4 mm



CARATTERISTICHE TECNICHE/ TECHNICAL FEATURES

Incastro Joint		i4F	Strato di usura Wear layer		0.3 mm
Bisello Bevel		Micro 4v			
Reazione al fuoco a pavimento* Flooring fire reaction*		Bfl-s1			
Reazione al fuoco a parete** Wall fire reaction**		B-s2, d0			

* Classificazione valida con l'utilizzo dei sottopavimenti e/o modalità indicate da Skema S.p.A. (per dettagli vedi scheda tecnica del prodotto e/o istruzioni per l'installazione).
* Classification valid with the use of underlayer and/or modality specified by Skema S.p.A. (please see product technical data sheet and/or installation instructions for details).

** Classificazione valida con modalità indicate da Skema S.p.A. (per dettagli vedi scheda tecnica del prodotto e/o istruzioni per l'installazione).
** Classification valid with the modality specified by Skema S.p.A. (please see product technical data sheet and/or installation instructions for details).

SPECIFICHE E CONFORMITÀ / SPECIFICATIONS AND COMPLIANCE



CONFEZIONAMENTO/ PACKAGING

Rif. formato/ Size	Pezzi Cfz/ Pieces Box	m ² Cfz/ Box	Cfz Pallet/ Box Pallet	m ² Pallet
1210x457 mm	5	2,765	40	110,642

Star KW Maxi

Grandi lastre a ridotto spessore per nuove realizzazioni o ristrutturazioni.

Large thin slabs: the smart choice for new projects and renovations.

Star KW Maxi trasferisce alle pareti il fascino senza tempo di marmi e graniglie superando i limiti tecnici ed espressivi di un normale rivestimento. Leggero, sottile e impermeabile grazie alla tecnologia SPC (Stone Polymer Composite), è la scelta ideale per ristrutturazioni e nuove realizzazioni in ambienti umidi come bagni, cucine ma anche living, ingressi oppure hall di grandi dimensioni. Il grande formato stimola la creatività progettuale, semplifica la posa e garantisce superfici continue, prive di interruzioni visive. Con Star KW Maxi estetica e funzionalità si fondono, offrendo rivestimenti scenografici, moderni e durevoli che valorizzano ogni progetto di interior design.

Star KW Maxi brings to walls the timeless charm of marble and terrazzo, transforming it into a contemporary and versatile solution. Lightweight, slim, and waterproof thanks to SPC (Stone Polymer Composite) technology, it is the ideal choice for renovations and new projects in humid environments as bathrooms and kitchens, but also living areas, entrances, or large halls. The large format inspires design creativity, simplifies installation, and ensures continuous surfaces free from visual interruptions. With Star KW Maxi, aesthetics and functionality come together to deliver scenographic, modern, and durable wall coverings that enhance every interior design project.



Product

Star KW Maxi - Graniglia Cotton 1261

GRANIGLIA COTTON/ 1261

stone

✓ 950x2800x4 mm

MARMO OROBICO/ 1262

stone

950x2800x4 mm

MARMO CARRARA/ 1263

stone

950x2800x4 mm



GRANIGLIA CLOUD/ 1264

stone

950x2800x4 mm



GRANIGLIA CASHMERE/ 1265

stone

950x2800x4 mm

MARMO CALACATTA/ 1266

stone

950x2800x4 mm

GRANIGLIA TUNDRA/ 1260

stone

950x2800x4 mm



Dati tecnici Technical data

STRATIGRAFIA/ STRATIGRAPHY

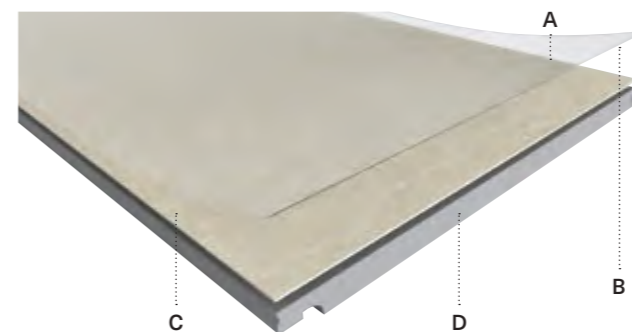

- A. Rivestimento anti-UV**
Anti-UV Coating
- B. Strato protettivo "Shell Star"**
Protective "Shell Star" layer
- C. Film vinilico decorativo**
Vinyl decorative film
- D. Cor.Star pannello in tecnologia SPC**
Cor.Star panel in SPC technology

FORMATI/ FORMATS

Star KW Maxi
950x2800x4 mm

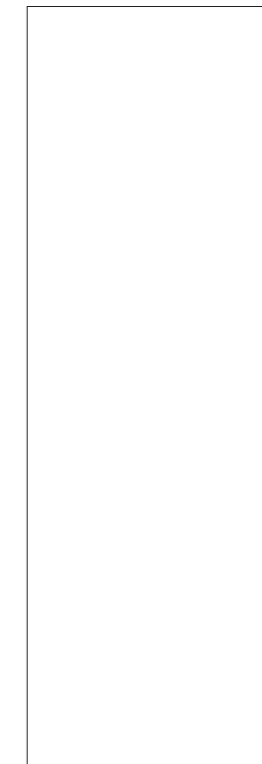

CARATTERISTICHE TECNICHE/ TECHNICAL FEATURES

Incastro Joint		i4F Su due lati lunghi On two long sides
Bisello Bevel		Micro 2v Su due lati lunghi On two long sides
Reazione al fuoco* Fire reaction*		B-s2, d0
Strato di usura Wear layer		0.3 mm

* Classificazione valida con modalità indicate da Skema S.p.A. (per dettagli vedi scheda tecnica del prodotto e/o istruzioni per l'installazione).
* Classification valid with the modality specified by Skema S.p.A. (please see product technical data sheet and/or installation instructions for details).

SPECIFICHE E CONFORMITÀ/ SPECIFICATIONS AND COMPLIANCE



CONFEZIONAMENTO/ PACKAGING

Rif. formato/ Size	Pezzi Cfz/ Pieces Box	m ² Cfz/ Box	Cfz Pallet/ Box Pallet	m ² Pallet
950x2800 mm	2	5,320	23	122,36

RIVESTIMENTI A PARETE E SOFFITTO/ WALL AND CEILING COVERINGS

ACCESSORI
ACCESSORIES

Sottopavimenti Underlayers

SUPERIOR RBR



Alte performance; densità media 800 kg/m³; soddisfa lo standard EPLF; ottima resistenza meccanica CS a protezione dell'incastro; alta performance acustica IS per riduzione riverbero in stanza RWS; bassa resistenza termica TR, consigliato per posa su massetti radianti; barriera vapore integrata (PET/Alu); bassissima emissione VOC; posa lato PET/Alluminio verso l'alto.
High performance; average density 800 kg/m³; fulfils EPLF standards; excellent mechanical resistance CS to protect the joint; high acoustic performance IS for room reverberation reduction RWS; low thermal resistance TR, recommended for laying on radiant screeds; integrated vapour barrier (PET/Alu); very low VOC emission; PET/Alu side up laying.

Dimensioni
Size

Rotolo/ Roll 8x1 m
Sp. 2 mm | D 800 kg/mc

BARRIERA VAPORE BN MOISTURE BARRIER BN



Foglio in polietilene coestruso ultrasottile, con uno spessore di 10 micron. La funzione principale è creare una barriera antivapore, proteggendo il pavimento dall'umidità che potrebbe risalire dagli elementi costruttivi. È facile da posare e rappresenta una soluzione efficace per mantenere il pavimento asciutto e duraturo.
Ultra-thin co-extruded polyethylene sheet, 10 microns thick. Its main function is to act as a vapor barrier, isolating the floor and protecting it from moisture rising from adjacent structural elements. This product is easy to install, and provides an effective solution for keeping floors dry and long-lasting.

Dimensioni
Size

Rotolo/ Roll da 30 mq - 25x1,2 m
Sp.100 my | D 0,93g/cm³

Rotolo/ Roll da 60 mq - 50x1,2 m
Sp.100 my | D 0,93g/cm³

Rotolo/ Roll da 120 mq - 100x1,2 m
Sp.100 my | D 0,93g/cm³

DB



Costituito da schiuma poliolefinica a celle chiuse estrusa in modalità controllata; densità media 80kg/m³; soddisfa standard EPLF; resistenza meccanica CS; isolamento al rumore da calpestio IS; barriera vapore SD (PET) che evita diffusione di umidità di risalita, integrata con cimosa laterale dotata di nastro adesivo applicato per congiunzione materassini; senza CFC e HCFC, plastificanti e metalli pesanti; posa con lato nero con barriera vapore verso l'alto.
Consisting of closed-cell polyolefin foam extruded in a controlled mode; average density 80 kg/m³; fulfils EPLF standard; mechanical resistance CS; impact sound insulation IS; vapour barrier SD (PET) preventing diffusion of moisture, integrated with side selvage with adhesive tape applied for mattress connection; free of CFCs and HCFCs, plasticisers and heavy metals; laid with black side with vapour barrier facing upwards.

Dimensioni
Size

Rotolo/ Roll 25x1 m
Sp. 2 mm | D 80 kg/mc

ST



Costituito da schiuma poliolefinica a celle chiuse estrusa in modalità controllata; densità media 20kg/m³; soddisfa standard EPLF; resistenza meccanica CS; isolamento al rumore da calpestio IS; barriera vapore SD (PET/Alluminio) integrata che evita diffusione di umidità di risalita; senza CFC e HCFC, plastificanti e metalli pesanti; posare con lato metallizzato verso l'alto.
Consisting of closed-cell polyolefin foam extruded in a controlled manner; average density 20 kg/m³; meets EPLF standard; mechanical resistance CS; impact sound insulation IS; integrated SD vapour barrier (PET/Aluminium) that prevents the diffusion of rising damp; free of CFCs and HCFCs, plasticisers and heavy metals; lay with metallised side up.

Dimensioni
Size

Rotolo/ Roll 25x1 m
Sp. 2 mm | D 20 kg/mc

Rotolo/ Roll 150x1 m
Sp. 2 mm | D 20 kg/mc

Battiscopa Skirting boards

STAR



Battiscopa in HDF con proporzioni standard.
HDF skirting board with standard proportions.

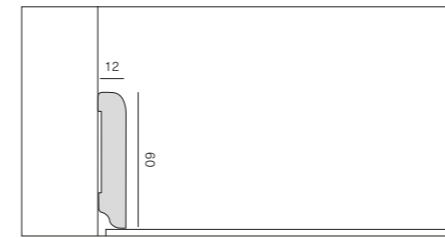

TIME



Battiscopa in HDF.
Skirting board made of HDF.

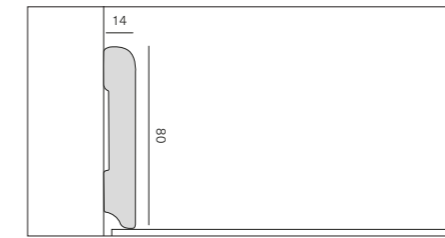

LOOK



Battiscopa in HDF con finitura poro.
Skirting board made of HDF with a pore finish.

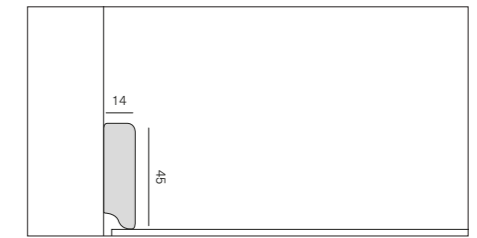

ABACO / RECAP

	STAR	TIME	LOOK
Abbinati Matching	Facile+	Prestige L Prestige Gold	Prestige L Prestige Gold Vision Technic
Abbinabili Combined	Syncro Parquet	Lumbertech	-
Tinta unita Solid colors	○ Bianco opaco/ Matt white	○ Bianco lucido/ Glossy white ○ Bianco opaco/ Matt white ○ Grigio chiaro/ Light grey ● Grigio medio/ Medium grey ● Grigio scuro/ Dark grey ● Nero opaco/ Matt black ● Carbonio/ Carbon ○ Beige ○ Avorio/ Ivory ● Metallo bronzo/ Bronze metal	● Alluminio/ Aluminum ○ Bianco lucido/ Glossy white ○ Bianco opaco/ Matt white ○ Grigio chiaro/ Light grey ● Grigio medio/ Medium grey ● Grigio scuro/ Dark grey ● Nero opaco/ Matt black ● Carbonio/ Carbon ○ Beige ○ Avorio/ Ivory ● Metallo bronzo/ Bronze metal
Dimensioni Size	h 60-2400x12 mm	h 80-2400x14 mm	h 45-2400x14 mm h 45-2200x14 mm

ACCESSORI/ ACCESSORIES

DROP

PVC ESPANSO

F

W45

W75

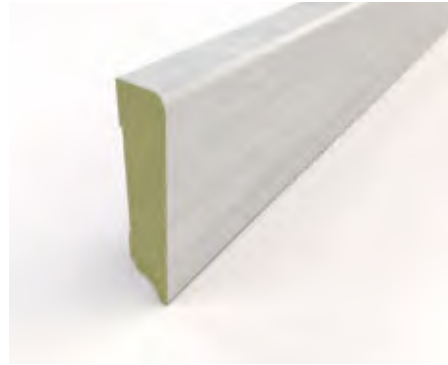

Battiscopa in HDF a bassa assorbenza con finiture poro. Con densità di 700 kg/m³ offre alta resistenza all'umidità.
HDF skirting board with low absorbency and a sealed finish. Its 700 kg/m³ density ensures high moisture resistance.

Battiscopa in PVC espanso resistente all'umidità.
Moisture-resistant expanded PVC skirting board.

Battiscopa realizzato con sistema folding utilizzando le relative doghe del pavimento.
Skirting board made with a folding system using the matching floor planks.

Profilo per battiscopa realizzato in MDF rivestito di tranciato di vero legno con finiture verniciate a poro aperto (gruppo 1) e, per i colorati, con stampa digitale successivamente verniciato (gruppo 2).
Skirting board profile made of MDF and covered with real wood veneer. Two types of finishings available: open pore varnished finishing (group 1) and a coloured finishing made by digital printing process and then varnished (group 2).

Profilo per battiscopa realizzato in MDF rivestito di tranciato di vero legno con finiture verniciate a poro aperto (gruppo 1) e, per i colorati, con stampa digitale successivamente verniciato (gruppo 2).
Skirting board profile made of MDF and covered with real wood veneer. Two types of finishings available: open pore varnished finishing (group 1) and a coloured finishing made by digital printing process and then varnished (group 2).

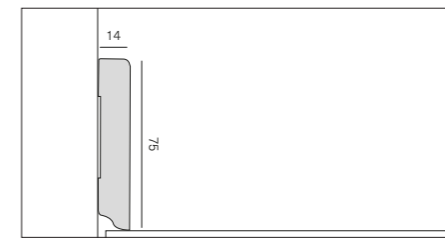
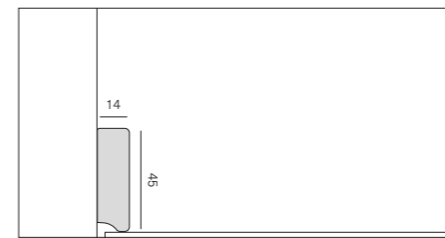
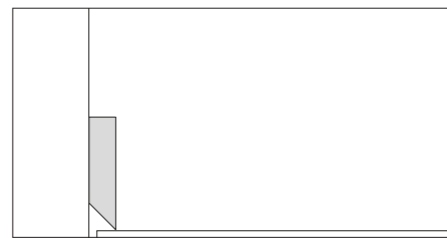
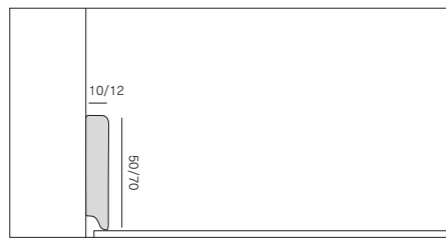
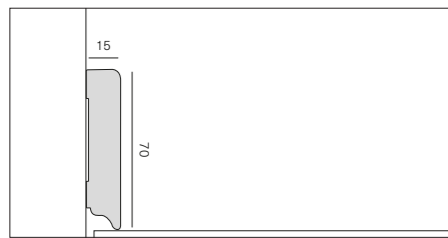

ABACO / RECAP

	DROP	PVC ESPANSO	F
Abbinati Matching	K-Uno	Star K Star KR Star KC Star KD Connex	Yles Palladio Villa
Abbinabili Combined	-	Star KS Star Wood Star Wood Spina	-
Tinta unita Solid colors	○ Bianco/ White - RAL 9003, 9010	○ Bianco/ White - RAL 9003, 9010 ● Nero/ Black ● Alluminio/ Aluminum - RAL 9006	-
Dimensioni Size	h 70-2400x15 mm	h 50-2400x12 mm h 70-2400x12 mm	Variabile/ Variable

ABACO / RECAP

	W45	W75
Abbinati Matching	Yles Palladio Villa	Yles Palladio Villa
Dimensioni Size	h 45-2400x14 mm	h 75-2400x14 mm

Profili

Profiles

PARAGRADINO ANTISDRUCCIOLO
NO-SLIP STAIR PROTECTOR



Paragradino antisdrucciolo in alluminio, che consente di rivestire il raccordo tra alzata e pedata di una scala.
Acquistare sempre con antiscivolo autoadesivo.
Non-slip aluminum stair nosing, used to cover the transition between the riser and tread of a staircase. Always purchase with self-adhesive non-slip tape.

ANGOLARE AD L
L-SHAPED CORNER PROFILE

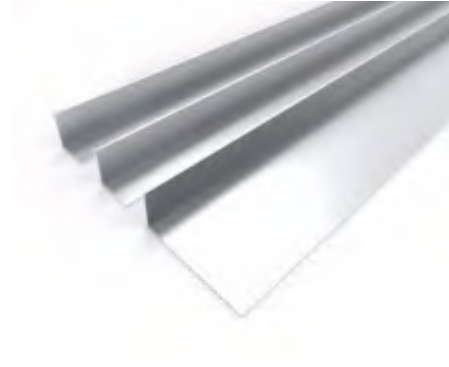

Profilo in alluminio per finiture di raccordi a muro.
Aluminium profile for finishing wall connections.

PROFILO DI BORDO
BORDER PROFILE

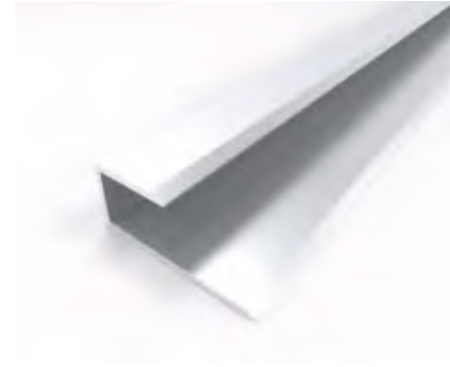

Profilo in alluminio estruso per bordature perimetrali per pavimenti.
Extruded aluminium profile for perimeter edging of floors.

PROFILO DI BORDO CURVABILE
CURVABLE BORDER PROFILE



Profilo in alluminio estruso curvabile per bordature perimetrali.
Extruded curvable aluminium profile for perimeter edging.

PROFILO SCALA 45°
45° STAIR PROFILE



Profilo paragradino in alluminio anodizzato argento per protezione e finitura arrotondata degli angoli esterni.
Silver anodized aluminum step nosing profile for protection and rounded finishing of external corners.

PROFILO SCALA LUMBERTECH
LUMBERTECH STAIR PROFILE

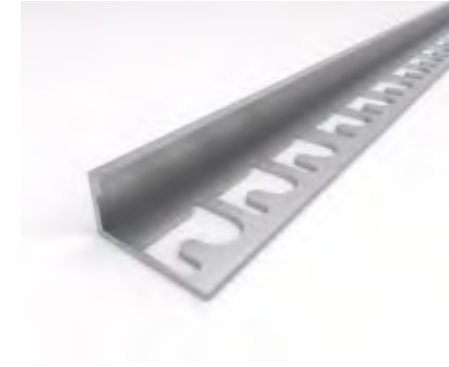

Profilo a L in alluminio anodizzato argentato per rivestire i gradini, utilizzando le stesse doghe utilizzate per il pavimento.
L-shaped profile in silver anodized aluminum to cover the steps, using the same slats used for the floor.

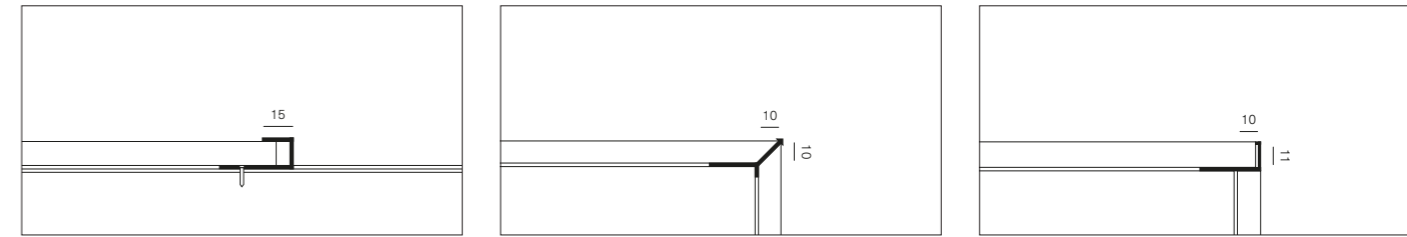
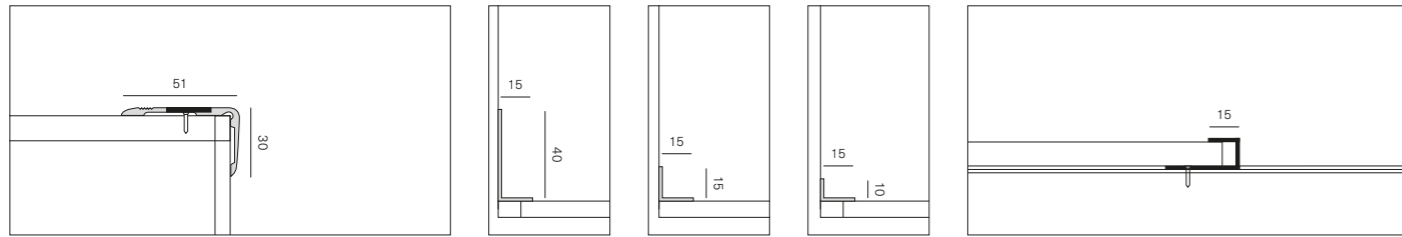

ABACO / RECAP

	PARAGRADINO ANTISDRUCCIOLO NO-SLIP STAIR PROTECTOR	ANGOLARE AD L L-SHAPED CORNER PROFILE	PROFILO DI BORDO BORDER PROFILE
Collezioni Lines	Pavimenti tecnici/ Technical flooring SPC Legni/ Wood	Pavimenti tecnici/ Technical flooring SPC Legni/ Wood	Pavimenti tecnici/ Technical flooring SPC Legni/ Wood
Tinta unita Solid colors	● Argento anodizzato/ Anodized silver ● Oro anodizzato/ Anodized gold ● Bronzo anodizzato/ Anodized bronze	● Argento/ Silver ● Bronzo/ Bronze	● Argento/ Silver ● Oro/ Gold
Dimensioni Size	3400x52x30 mm 18 m rotolo striscia antiscivolo autoadesiva/ 18 m roll self-adhesive non-slip strip	● 2000/3000x15x10 mm spessore 1,0 mm/ 1.0 mm thick ● 2000x15x15 mm spessore 1,5 mm/ 1.5 mm thick ● 2000x45x40 mm spessore 2,0 mm/ 2.0 mm thick	2700x15x6 mm 2700x15x7 mm 2700x15x9 mm 2700x15x11 mm 2700x15x15 mm

ABACO / RECAP

	PROFILO DI BORDO CURVABILE CURVABLE BORDER PROFILE	PROFILO SCALA 45° 45° STAIR PROFILE	PROFILO SCALA LUMBERTECH LUMBERTECH STAIR PROFILE
Collezioni Lines	Pavimenti tecnici/ Technical flooring SPC Legni/ Wood	-	-
Collezioni abbinate Matching lines	-	K-Uno	Lumbertech
Tinta unita Solid colors	● Argento/ Silver ● Oro/ Gold ● Bronzo/ Bronze	● Argento/ Silver	● Argento/ Silver
Dimensioni Size	Pavimenti tecnici/ Technical flooring ● 2700x15x9 mm - 2700x15x11 mm SPC ● 2700x15x7 mm Legni/ Wood ● 2700x15x11 mm ● 2700x15x13 mm - 2700x15x15 mm	3000x10 mm spessore 10 mm/ 10 mm thick	2700x11 mm spessore 11 mm/ 11 mm thick

PROFILO SCALA SINTESY
SINTESY STAIR PROFILE

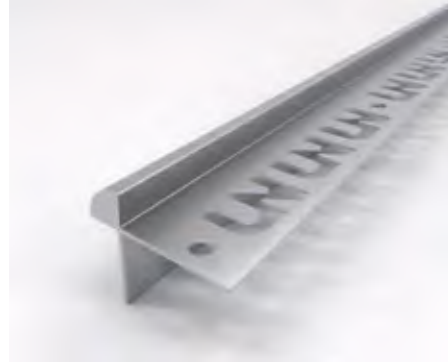

Profilo scala in alluminio anodizzato argento, per rivestire i gradini con le stesse doghe utilizzate per realizzare il pavimento.
Anodized Silver anodized aluminum profile to cover the steps with the same planks used for the flooring.

TORO SCALA F
F STAIR NOSE



Toro scala realizzato con sistema folding utilizzando le relative doghe del pavimento, così da ottenere un perfetto abbinamento con lo stesso.
Verificare con ufficio tecnico la fattibilità nella finitura desiderata.
Stair nose made with folding system using the same planks of the floor, in order to obtain a perfect match with the same. Check with the technical office the feasibility in the desired finish.

TORO SCALA 30x30
STAIR NOSE 30x30



Toro scala in massello con spessori 10 mm e 15 mm; su richiesta il profilo può essere fornito anche stondato.
Solid wood stair bullnose with thicknesses of 10 mm and 15 mm; upon request, the profile can also be supplied with a rounded edge.

TORO SCALA 100x30
STAIR NOSE 100x30



Toro scala in massello con spessori 10 mm e 15 mm; su richiesta il profilo può essere fornito anche stondato.
Solid wood stair bullnose with thicknesses of 10 mm and 15 mm; upon request, the profile can also be supplied with a rounded edge.

TORO SCALA ELITE
ELITE STAIR NOSE



Toro scala in HDF, da abbinare esclusivamente alla maschiatura sul lato lungo dei pavimenti. Fissaggio con collante specifico.
HDF stair bullnose, to be combined exclusively with the tongue on the long side of the flooring. Fix with specific adhesive.

KIT DILATAZIONE
EXPANSION KIT



Kit dilatazione abbinabile e in alluminio con Pin Unico per pavimenti con spessore da 6 a 12,5 mm, con base femmina in alluminio.
Aluminum expansion kit with Single Pin for floorings with thickness from 6 to 12,5 mm and aluminum female base.

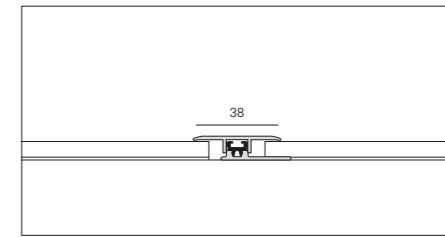
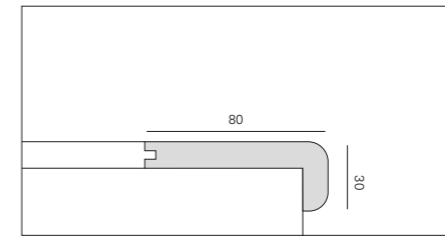
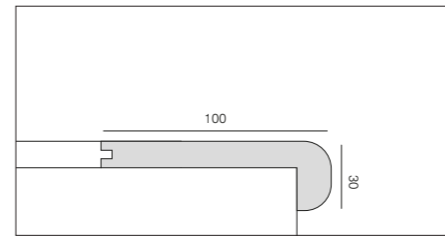
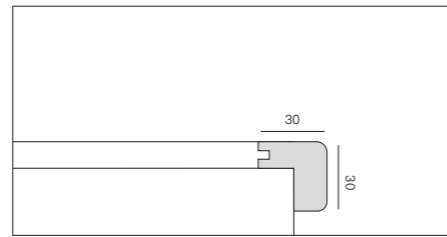
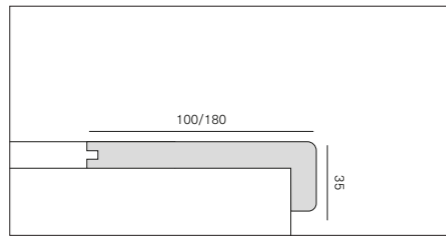
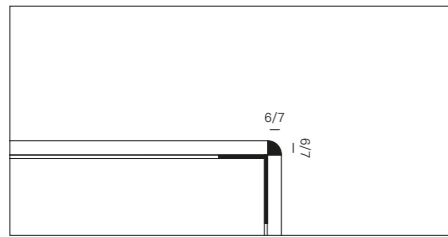

ABACO / RECAP

	PROFILO SCALA SINTESY SINTESY STAIR PROFILE	TORO SCALA F F STAIR NOSE	TORO SCALA 30x30 STAIR NOSE 30x30
Collezioni Lines	SPC	-	-
Abbinati Matching	-	Palladio Villa	Palladio Villa
Abbinabili Combined	-	Yes	-
Tinta unita Solid colors	● Argento/ Silver	-	-
Dimensioni Size	2700x6 mm Star Wood - Star Wood Spina 2700x7 mm	Palladio 1850/2150x100/135/180x35 mm Yes Variabile/ Variable	30x30x1200 mm

ABACO / RECAP

	TORO SCALA 100x30 STAIR NOSE 100x30	TORO SCALA ELITE ELITE STAIR NOSE	KIT DILATAZIONE EXPANSION KIT
Collezioni Lines	-	-	Pavimenti tecnici/ Technical flooring Legni/ Wood
Abbinati Matching	Palladio Villa	K-Uno Prestige L Prestige Gold	K-Uno Prestige L Prestige Gold Facile+ Vision Oxid Vision Technic Lumbertech
Abbinabili Combined	-	-	Syncro Parquet
Tinta unita Solid colors	-	-	● Argento anodizzato/ Anodized silver
Dimensioni Size	100x30x1200 mm	2430x80x30 mm K-Uno spessore 10 mm/ 10 mm thick Prestige L - Prestige Gold spessore 8 mm/ 8 mm thick	2700x38 mm

KIT DILATAZIONE DA 5 A 7 MM
EXPANSION KIT 5 TO 7 MM

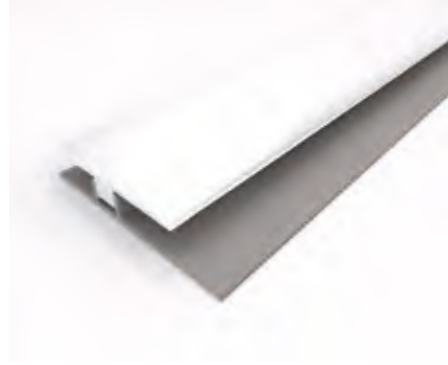

Kit dilatazione in alluminio per pavimenti con spessore da 5 a 7 mm, con base femmina in PVC. Aluminum expansion kit for floorings with thickness from 5 to 7 mm and PVC female base.

DILATAZIONE SINTESY
SINTESY EXPANSION



Profilo di dilatazione in alluminio anodizzato argenteo autoadesivo. Self-adhesive silver anodized aluminium expansion profile.

DISLIVELLO SINTESY
SINTESY SPLICE PROFILE



Profilo di dislivello in alluminio anodizzato autoadesivo per pavimenti con spessore da 4 a 6 mm. Self-adhesive anodized aluminium transition profile for 4-6 mm floors.

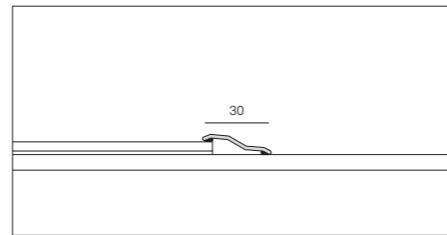
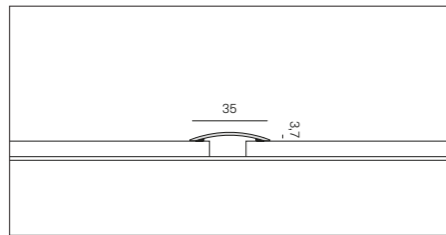
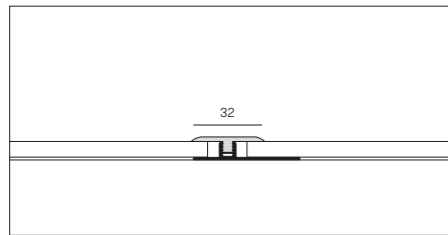

ABACO / RECAP

	KIT DILATAZIONE DA 5 A 7 MM EXPANSION KIT 5 TO 7 MM	DILATAZIONE SINTESY SINTESY EXPANSION	DISLIVELLO SINTESY SINTESY SPLICE PROFILE
Collezioni Lines	SPC	SPC	-
Abbinati Matching	Star K Star KR Star KC Star KS Star KD Connex	-	Star K Star KR Star KC Star KS Star KD Connex
Abbinabili Combined	Star KS Star Wood Star Wood Spina	-	-
Tinta unita Solid colors	● Argento anodizzato/ Anodized silver	● Argento satinato/ Satin silver	● Argento anodizzato/ Anodized silver
Dimensioni Size	2700x32 mm	2700x35 mm	2700x29 mm

KIT DISLIVELLO DA 6 A 12,5 MM
SPLICE KIT 6 TO 12,5 MM



Kit dislivello in alluminio con Pin Unico per pavimenti con spessore da 6 a 12,5 mm con base femmina in alluminio. Aluminium transition kit with Single Pin for floors with thickness from 6 to 12.5 mm, with aluminium female base.

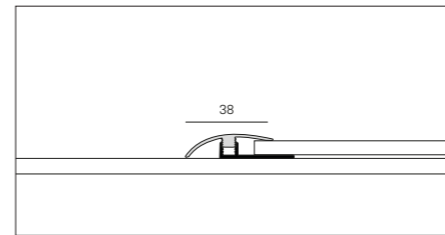

KIT DISLIVELLO DA 5 A 7 MM
SPLICE KIT 5 TO 7 MM



Kit dislivello in alluminio o abbinato per pavimenti con spessore da 5 a 7 mm con base femmina in PVC. Aluminum splice or matching kit for floorings with thickness from 5 to 7 mm, with PVC female base.

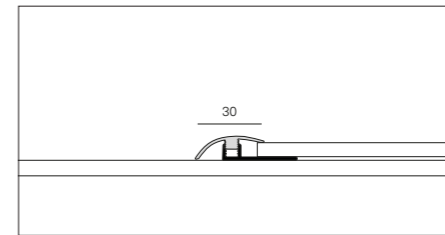

KIT TERMINALE
TERMINAL KIT



Kit terminale in alluminio con Pin Unico per pavimenti con spessore da 9 a 12,5 mm con base femmina in alluminio. Aluminium end kit with Single Pin for floors with thickness from 9 to 12.5 mm, with aluminium female base.

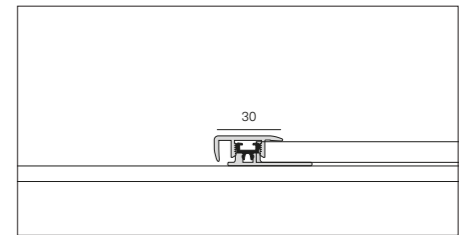

ABACO / RECAP

	KIT DISLIVELLO DA 6 A 12,5 MM SPLICE KIT 6 A 12,5 MM	KIT DISLIVELLO DA 5 A 7 MM SPLICE KIT 5 TO 7 MM	KIT TERMINALE TERMINAL KIT
Collezioni Lines	-	-	Pavimenti tecnici/ Technical flooring Legni/ Wood
Abbinati Matching	Pavimenti tecnici/ Technical flooring	Star K Star KR Star KC Star KD	-
Abbinabili Combined	-	Star KS	-
Tinta unita Solid colors	● Argento anodizzato/ Anodized silver	● Argento anodizzato/ Anodized silver	● Argento/ Silver
Dimensioni Size	2700x38 mm 2700x45 mm	2700x30 mm	2700x30 mm

Accessori per pavimenti sopraelevati Accessories for raised floors

KIT TERMINALE DA 5 A 7 MM
TERMINAL KIT FROM 5 TO 7 MM



Kit terminale in alluminio per pavimenti con spessore da 5 a 7 mm con base femmina in PVC.
Aluminium end kit for floors with thickness from 5 to 7 mm, with PVC female base.

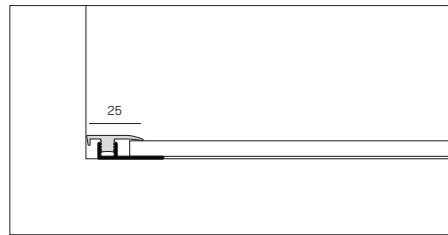

SISTEMA FOLDING PER SPC
FOLDING SYSTEM FOR SPC



L'elemento "folding" si presenta con una piega a 90°, adatto per rivestire scalini ad angolo retto.
Solo per residenziale.
The "folding" element has a 90° bend, suitable for covering right-angled steps.
For residential use only.

CLIP DI AGGANCIAMENTO
RETAINING CLIP



Clip di aggancio in metallo zincato nero che, con rotazione sull'omega, fissa pannelli e doghe alla struttura.
Black galvanized metal clip that, by rotating onto the omega, secures panels and slats to the structure.

COLONNA BASE FILETTATA
COLUMN WITH THREADED BASE



Altezza Min Max
Min-Max Height

40-60 mm
50-80 mm
60-100 mm
100-150 mm

COLONNA BASE INNESTATA
COLUMN WITH EMBEDDED BASE



Altezza Min Max
Min-Max Height

120-180 mm
140-190 mm
160-230 mm
190-260 mm
220-290 mm
260-330 mm
300-370 mm
340-410 mm
380-450 mm
420-490 mm
460-530 mm

TRAVERSO CON GUARNIZIONE BASIC
CROSS-PIECE WITH SEAL BASIC



Dimensioni
Size

35 mm
spessore 0,9 mm/ 0,9 mm thick

ABACO / RECAP

	KIT TERMINALE DA 5 A 7 MM TERMINAL KIT FROM 5 TO 7 MM	SISTEMA FOLDING PER SPC FOLDING SYSTEM FOR SPC	CLIP DI AGGANCIAMENTO RETAINING CLIP
Collezioni Lines	-	Star KD Star K Star KR Star KS Star KC Star KW	K-Uno Prestige L Lumbertech
Abbinati Matching	SPC	-	-
Tinta unita Solid colors	● Argento anodizzato/ Anodized silver	-	-
Dimensioni Size	2700x25 mm	Dimensione doga piegata (lunghezza x pedata x alzata) Folded plank size (length x tread x riser) Star KD 914x375x76 mm Star K 1828x140x72 mm Star KR 1500x140x74 mm 1828x150x72 mm Star KC 1500x148x74 mm Star KW Su richiesta/ On demand	44x41 mm
Confezione Packaging			200 pz/ pcs

Accessori per rivestimenti a parete e soffitto

Accessories for wall and ceiling coverings

PROFILO SPIGOLO A Y
Y-EDGE



PROFILO COMPLETAMENTO
COMPLETION KIT



PROFILO SPIGOLO QUADRATO
SQUARE EDGE



ABACO / RECAP

	PROFILO SPIGOLO A Y Y-EDGE	PROFILO COMPLETAMENTO COMPLETION KIT	PROFILO SPIGOLO QUADRATO SQUARE EDGE
Collezioni Lines	Star KW	Star KW	Star KW
Dimensioni Size	2700x4,5 mm	2700x4,5 mm	2700x4,5 mm

PROFILO SPIGOLO TONDO
ROUND EDGE



PROFILO OMEGA
OMEGA PROFILE

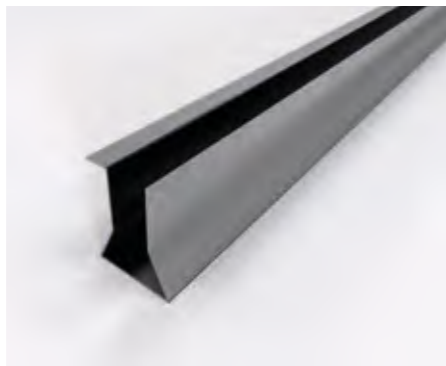

PROFILO JOLLY
JOLLY PROFILE

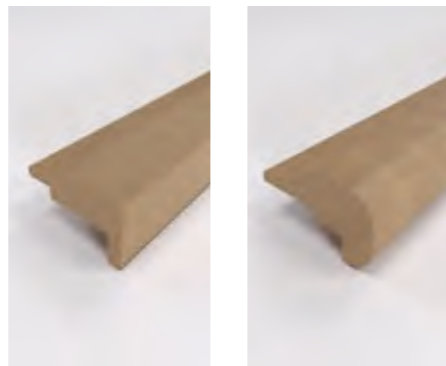

Il profilo ad omega costituisce l'elemento per il fissaggio a parete tramite viti o tasselli e deve essere montato ad una struttura portante tipo cartongesso o al muro da rivestire.
Omega cross-section profile is the element that fastens the boards to the wall. It must be installed using screws or wall plugs to a load bearing structure, such as drywall or the wall to be covered.

Profilo in MDF sagomato per tamponamento laterale del rivestimento a parete Tech Wall.
La forma squadrata è ideale per le doghe TW1 e TW2, la forma arrotondata per le doghe TW3.
Shaped MDF profile for the lateral closure of the Tech Wall cladding.
The squared shape is ideal for TW1 and TW2 slats, while the rounded shape is suitable for TW3 slats.

ABACO / RECAP

	PROFILO SPIGOLO TONDO ROUND EDGE	PROFILO OMEGA OMEGA PROFILE	PROFILO JOLLY JOLLY PROFILE
Collezioni Lines	Star KW	-	Tech Wall
Tinta unita Solid colors	-	-	<ul style="list-style-type: none"> ● Raw Oak ● Nux ● Paint ● Timber ● Nero/ Black
Dimensioni Size	2700x4,5 mm	3000x25x26 mm 3000x13x26 mm	3040x32x20 mm 3040x29,4x18,4 mm

Posa

Laying

KIT MORSETTI TELESCOPICI
TELESCOPIC CLAMP KIT



In fase di partenza il muro non è mai regolare. I morsetti permettono di registrare la distanza tra muro e pavimento in senso longitudinale, accelerando le fasi di posa di un pavimento flottante. Consigliati 2 kit per posatore.
When starting, walls are never perfect. These clamps allow you to register the horizontal distance between the wall and the flooring, for more rapid installation.
2 kits per installer are recommended.

Collezioni Lines	Pavimenti tecnici/ Technical flooring Legni/ Wood

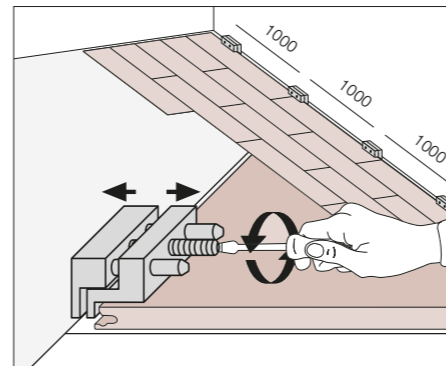

GRIMALDELLO
PICKLOCK



È indispensabile per completare l'ultima fila di pavimento, in quanto non c'è spazio per la manovra del martello. Solo per incastri SLS e PLS (no TLS). Consigliati 1 pezzo per posatore.
This tool is required for finishing the last row of the flooring as there is no place enough for using the hammer.
We recommend 1 tool per installer.

Collezioni Lines	Pavimenti tecnici/ Technical flooring Legni/ Wood

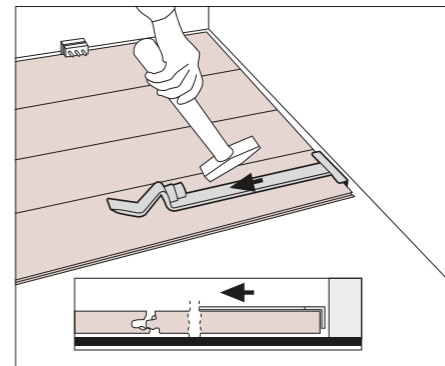

TENSIONATORE CINGHIA
BELT TENSIONER



Per pavimenti con incastro a colla. Strumento per compattare le prime tre/ quattro file di doghe, fondamentali per la buona riuscita del lavoro soprattutto con colori chiari su incastri tradizionali a colla. Consigliati 6 pezzi per posatore.
For floorings with glued joints. Fundamental for good installation, especially for light colours with traditional glued joints.
6 units per installer are recommended.

Collezioni Lines	Pavimenti tecnici/ Technical flooring Legni/ Wood

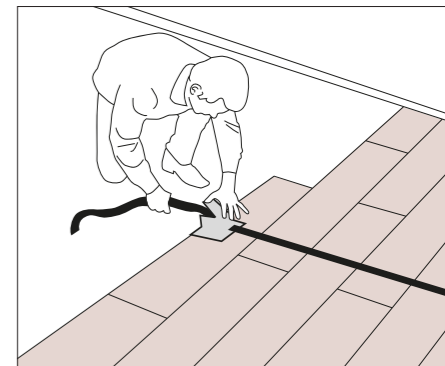

DISTANZIATORE PER PAVIMENTI FLOTTANTI
SPACER FOR FLOATING FLOORING



Nei casi in cui si debba fissare al pavimento elementi di arredo o funzionali, consente di evitare il bloccaggio delle dilatazioni del pavimento e conseguenti sollevamenti dello stesso.
If you need to fasten pieces of furniture or functional elements to the flooring, it avoids blocking the flooring expansion and its consequent raising.

DISTANZIATORE PER PAVIMENTI AV2
AV2 SPACER FOR FLOORING



Distanziatore in plastica per pavimenti flottanti, regolabile 5–20 mm.
Plastic spacer for floating floors, adjustable 5–20 mm.

BATTITAVOLA PAVIMENTI TECNICI
TECHNICAL FLOORING STAVES ALIGNER



Indispensabile per raccordare le doghe. Consigliato 1 pezzo per posatore.
Avvertenza: Usare esclusivamente battitavola originali per evitare di danneggiare l'incastro in modo irreparabile.
Indispensable for aligning the edge of the panels. We recommend 1 tool per installer.
Notice: Use only original Staves Aligner to avoid irreparable damages to the joint.

COLLA NUNIVIL 1008 (D3)
GLUE NUNIVIL 1008 (D3)



Adesivo acetovinilico per pavimenti flottanti con incastro M/F. Consumo medio 35–40 g/m².
Consultare la documentazione tecnica sul sito.
Special vinyl adhesive for floating floors with M/F joint. Average consumption 35–40 g/m².
Refer to the technical documentation on the website.

COLLA ISOCOLL 6307 BEIGE PER BATTISCOPA PVC ESPANSO
GLUE ISOCOLL 6307 BEIGE FOR EXPANDED PVC SKIRTING BOARDS



Colla poliuretanica monocomponente per un ottimo fissaggio del battiscopa in PVC espanso su diverse superfici.
Single component polyurethane adhesive for excellent fastening of expanded PVC skirting board on different surfaces.

COLLA ISOCOLL ECO 6056 BIANCO PER SCALE BATTISCOPA
GLUE ISOCOLL ECO 6056 WHITE FOR STEPS AND SKIRTING BOARDS



Colla monocomponente per il fissaggio del battiscopa e incollaggio gradini.
Single component adhesive for fastening skirting and stair elements.

Collezioni Lines Pavimenti tecnici/ Technical flooring

Collezioni Lines Pavimenti tecnici/ Technical flooring Legni/ Wood

Collezioni Lines Pavimenti tecnici/ Technical flooring

Collezioni Lines Pavimenti tecnici/ Technical flooring Legni/ Wood

Collezioni Lines SPC

Collezioni Lines Pavimenti tecnici/ Technical flooring Legni/ Wood

Confezione Packaging 500 gr

Confezione Packaging 290 ml

Confezione Packaging 290 ml

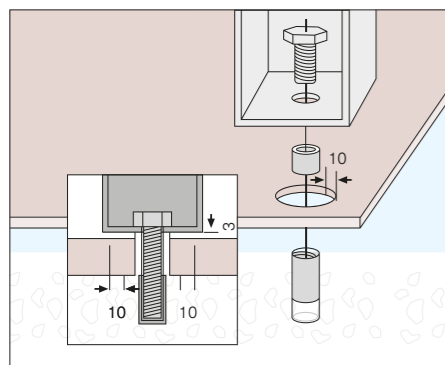

ACCESSORI DI MONTAGGIO
INSTALLATION ACCESSORIES



Accessori complementari utili per un lavoro preciso e veloce.
Accessories complementary for accurate, rapid installation.

Collezioni Lines Pavimenti tecnici/ Technical flooring

Cura e manutenzione

Care and maintenance

PULISYSTEM



Detergente igienizzante.
Sanitizing detergent.

Collezioni Lines Pavimenti tecnici/ Technical flooring Lumbertech SPC

Confezione Packaging 1 L

SANITOTAL



Detergente decontaminante.
Attenzione: da utilizzarsi dopo aver lavato le superfici con il prodotto pulisystem.
Decontaminant detergent.
Warning: use only after cleaning surfaces with Pulisystem.

Collezioni Lines Pavimenti tecnici/ Technical flooring Lumbertech SPC

Confezione Packaging 1 L

MULTILAYER CLEANER



Detergente antistatico sanificante adatto alla pulizia di pavimenti tecnici e vinilici.
Antistatic sanitizing cleaner for technical and vinyl flooring.

Collezioni Lines Pavimenti tecnici/ Technical flooring Lumbertech SPC

Confezione Packaging 1 L

OLIO PER RITOCOCCO RETOUCHING OIL



Olio per ritocco e ripristino.
Touch-up and restoration oil.

Collezioni Lines Lumbertech 270 Oil

Confezione Packaging 0,125 L

CLEANER STAR



Detergente intensivo multiuso per la pulizia di pavimenti in legno verniciati/ olio UV.
Intensive multipurpose cleaner for varnished and UV-oiled wooden floors.

Collezioni Lines Lumbertech 270 Varnish, 205, S700 Palladio

Confezione Packaging -

OSMO POLYX OIL 3062 MATT



Trattamento speciale di oliatura.
Special oiling treatment.

Collezioni Lines Lumbertech 270 Oil

Confezione Packaging -

WAX CARE SPRAY



Waxe care è una dispersione di cere idrorepellenti per la protezione di pavimenti in legno verniciati o oliati.
Waxe care is a dispersion of water-repellent waxes for protection of varnished or oiled wooden floors.

Collezioni Lines Star Wood Star Wood Spina Legni/ Wood

Confezione Packaging -

PARKETTREINIGER



Detergente per parquet a base di sapone naturale, pH neutro, ideale per la pulizia periodica di pavimenti in legno verniciati o oliati.
Parquet cleaner, natural soap-based, pH-neutral, ideal for regular cleaning of varnished or oiled wooden floors.

Collezioni Lines Lumbertech 270 Oil Palladio Yes

Confezione Packaging 1 L

DETERGENTE MANUTENTORE CEROSO WAXY MAINTENANCE CLEANER



Prodotto di manutenzione trasparente a base di cere naturali per il rinnovo ciclico dei pavimenti in legno.
Transparent maintenance product based on natural waxes for the cyclical renewal of wooden floors.

Collezioni Lines Lumbertech 270 Oil Palladio Yes

Confezione Packaging 1 L

**PACKAGING
E LOGISTICA**
PACKAGING
AND LOGISTICS

Pavimenti in legno

Wood flooring

Prodotto Product	Rif. formato mm Size mm	Pezzi Cfz Pieces Box	m² Cfz m² Box	Dimensioni scatola mm Box dimensions mm	Kg per scatola Kg per box	Cfz pallet Box pallet	m² pallet m² pallet	Dimensione pallet (mm) Pallet dimensions (mm)	Kg pallet al m² Pallet kg per m²	Peso lordo pallet Pallet Weight
PALLADIO	1850/2150/2350 x192x15	4	VAR	VAR	VAR	50	VAR	1870/2170/2370 x1000x750	8,39	VAR
	1850x2150x152x11	8	VAR	VAR	VAR	36	VAR	1870x2170x960x680	6,27	VAR
	650x120x15	10 (5dx+5sx)	0,988	665x162x150	6,195	28	VAR	670x1100x750	6,67	VAR
VILLA	2200x180x14	7	2,772	2215x190x105	22	25	69,3	2220x970x660	8,08	577
	1092x130x10	9	1,278	1157x140x100	7,8	49	62,6	1130x1050x830	6,34	412
	660x110x14	8 (4dx+4sx)	0,581	675x115x115	4,69	56	32,536	950x700x950	8,08	282
	550x110x14	8 (4dx+4sx)	0,484	690x125x115	3,91	56	27,104	1000x710x970	8,08	239
LUMBERTECH 270	2200x270x11	4	2,376	2235x295x49	23,46	30	71,28	2250x900x480	9,87	719
LUMBERTECH S700	700x140x11	10	0,98	730x160x120	10,36	56	54,88	1200x760x900	8,9	559
LUMBERTECH 205	2200x205x11	4	1,804	2230x210x50	20	40	72,16	2250x920x570	11,12	790

Pavimenti tecnici

Technical flooring

Prodotto Product	Rif. formato mm Size mm	Pezzi Cfz Pieces Box	m² Cfz m² Box	Dimensioni scatola mm Box dimensions mm	Kg per scatola Kg per box	Cfz pallet Box pallet	m² pallet m² pallet	Dimensione pallet (mm) Pallet dimensions (mm)	Kg pallet al m² Pallet kg per m²	Peso lordo pallet Pallet Weight
K-UNO	2052x248x10	4	2,035	2070x260x40	18,38	42	85,494	2110x830x750	9,03	787
SYNCRO PARQUET	1184x293x8	6	2,081	1210x305x50	16,14	51	106,3	1220x930x1000	7,75	839
	1182x293x8	6	2,078	1210x305x50	17,08	51	106,02	1220x930x1000	8,22	886
	1183x601x8	3	2,132	1210x610x25	18,32	68	145,40,00	1220x1230x1030	8,59	1261
PRESTIGE GOLD	1288x198x8	10	2,55	1302x210x80	18,9	40	102,01	1305x850x960	7,4	770
PRESTIGE L	2052x220x8	6	2,708	2069x236x48	20,12	36	97,511	2120x930x585	7,43	740
FACILE+	1288x198x8	10	2,55	1302x210x80	18,44	40	102,01	1305x850x960	7,23	753
VISION OXID	1183x396x8	5	2,34	1210x405x45	19,82	42	98,295	1220x830x1020	8,46	848
	1184x601x8	3	2,135	1210x610x25	17,02	68	145,163	1220x1230x1030	7,98	1172
VISION TECHNIC	857x398x8	7	2,387	870x410x55	17,65	30	71,61	1240x880x700	7,4	546

Pavimenti in SPC

SPC flooring

Prodotto Product	Rif. formato mm Size mm	Pezzi Cfz Pieces Box	m ² Cfz m ² Box	Dimensioni scatola mm Box dimensions mm	Kg per scatola Kg per box	Cfz pallet Box pallet	m ² pallet m ² pallet	Dimensione pallet (mm) Pallet dimensions (mm)	Kg pallet al m ² Pallet kg per m ²	Peso lordo pallet Pallet Weight
STAR K	1828x218x6	4	1,594	1860x240x30	17,14	68	108,452	1900x980x650	10,75	1181
		6	2,392	1845x230x42	25,10	48	114,819	1870x1000x665	10,75	1260
STAR KR	1500x220x6	6	1,980	1531x242x30	20,96	56	110,880	1570x988x435	10,59	1189
	1828x228x6	4	1,668	1840x240x26	17,38	68	113,415	1865x1010x640	10,42	1205
	1828x218x6	6	1,594	1860x240x30	25,10	48	114,819	1870x1000x665	10,42	1230
STAR KC	1500x228x6	6	2,052	1525x240x40	21,16	52	106,704	1535x975x670	10,31	1145
STAR KS	1498x300x6	6	2,696	1530x322x40	29,12	42	113,249	1570x670x1000	10,8	1225
STAR KD	914x457x6	6	2,506	940x480x40	25,38	40	100,247	970x980x1000	10,12	1030
CONNEX	1500x180x5,5	8	2,16	1515x195x50	19,26	50	108	1540x1000x660	8,92	978
STAR WOOD	1218x165x7	8	1,607	1240x182x60	20,8	72	125,405	1250x1110x910	12,94	1642
	1900x190x7	6	2,166	1928x182x60	20,8	55	119,13	1930x1040x665	12,93	1560
	600x100x7	14	0,84	620x110x100	10,56	144	120,96	1250x930x970	12,57	1540

Pavimenti sopraelevati

Raised flooring

Prodotto Product	Rif. formato mm Size mm	Pezzi Cfz Pieces Box	m ² Cfz m ² Box	Dimensioni scatola mm Box dimensions mm	Kg per scatola Kg per box	Cfz pallet Box pallet	m ² pallet m ² pallet	Dimensione pallet (mm) Pallet dimensions (mm)	Kg pallet al m ² Pallet kg per m ²	Peso lordo pallet Pallet Weight
TOP LEVEL LUMBERTECH	600x600x39/41	1	0,36	600x600	VAR	48/ 56	VAR	1260x660x960	VAR	VAR
TOP LEVEL PRESTIGE L	600x600x36/38	1	0,36	600x600	VAR	48/ 56	VAR	1260x660x960	VAR	VAR
TOP LEVEL VISION TECHNIC	600x600x36/38	1	0,36	600x600	VAR	48/ 56	VAR	1260x660x960	VAR	VAR

Rivestimenti a parete e soffitto

Wall and ceiling coverings

Prodotto Product	Rif. formato mm Size mm	Pezzi Cfz Pieces Box	m ² Cfz m ² Box	Dimensioni scatola mm Box dimensions mm	Kg per scatola Kg per box	Cfz pallet Box pallet	m ² pallet m ² pallet	Dimensione pallet (mm) Pallet dimensions (mm)	Kg pallet al m ² Pallet kg per m ²	Peso lordo pallet Pallet Weight
TECH WALL	3040x166x12	5	2,523	3050x173x65	19,98	44	111,012	3060x730x840	7,92	899,12
STAR KW	1210x457x4	5	2,765	1230x470x25	22,58	40	110,642	1260x960x630	8,16	918
STAR KW MAXI	950x2800x4	2	5,32	-	-	23	122,36	-	-	-

Skema S.p.A.

Via dell'Artigianato, 8
31047 Ponte di Piave (TV) - Italy

Ph. (+39) 0422 858511
info@skema.eu
www.skema.eu

A.D.

arch. paolo pampanoni

Concept & Graphic

d+a srl

Set design, rendering

virtual design
nudesign srl

Photo

studio antiorario

Printed

antiga

La riproduzione dei colori è approssimativa.

Skema S.p.A. ha la facoltà esclusiva di modificare e sostituire, anche solo parzialmente, i componenti dei sistemi illustrati in questo folder, senza l'obbligo di darne preavviso.

The reproduction of colors is approximate. Skema S.p.A. has the exclusive right to modify and replace, even only partially, the components of the systems illustrated in this folder, without the obligation to give prior notice.

© Copyright by Skema S.p.A.
All rights reserved

